



# ENERGY STAR<sup>®</sup> Program Requirements for Exit Signs

## Partner Commitments

### Commitment

The following are the terms of the ENERGY STAR Partnership Agreement as it pertains to the manufacturing of ENERGY STAR qualified exit signs. The ENERGY STAR Partner must adhere to the following program requirements:

- comply with current ENERGY STAR Eligibility Criteria, defining the performance criteria that must be met for use of the ENERGY STAR certification mark on exit signs and specifying the testing criteria for exit signs. EPA may, at its discretion, conduct tests on products that are referred to as ENERGY STAR qualified. These products may be obtained on the open market, or voluntarily supplied by Partner at EPA's request;
- comply with current ENERGY STAR Logo Use Guidelines, describing how the ENERGY STAR labels and name may be used. Partner is responsible for adhering to these guidelines and for ensuring that its authorized representatives, such as advertising agencies, dealers, and distributors, are also in compliance;
- qualify at least one ENERGY STAR labeled exit sign model within six months of activating the exit signs portion of the agreement. When Partner qualifies the product, it must meet the specification (e.g., Tier 1 or 2) in effect at that time;
- provide clear and consistent labeling of ENERGY STAR qualified exit signs. The ENERGY STAR label must be clearly displayed on the product packaging, in product literature (i.e., user manuals, spec sheets, etc.), and on the manufacturer's Internet site where information about ENERGY STAR qualified models is displayed;
- provide training materials for its product dealers and distributors. Materials shall describe ENERGY STAR and the Partner's participation in the program, provide information about energy-efficient exit signs as well as cost and maintenance savings, and identify models that comply with the ENERGY STAR Exit Sign specifications. Materials may include specification sheets, point of purchase displays, informational fact sheets, demonstration models, etc.
- provide to EPA, on an annual basis, an updated list of ENERGY STAR qualifying exit sign models. Once the Partner submits its first list of ENERGY STAR labeled exit sign models, the Partner will be listed as an ENERGY STAR Partner. Partner must provide annual updates in order to remain on the list of participating product manufacturers;
- provide to EPA, on an annual basis, unit shipment data or other market indicators to assist in determining the market penetration of ENERGY STAR. Specifically, Partner must submit the total number of ENERGY STAR qualified exit signs shipped (in units by model) or an equivalent measurement as agreed to in advance by EPA and Partner. Partner is also encouraged to provide ENERGY STAR qualified unit shipment data segmented by meaningful product characteristics (e.g., capacity, size, speed, or other as relevant), total unit shipments for each model in its product line, and percent of total unit shipments that qualify as ENERGY STAR. The data for each calendar year should be submitted to EPA, preferably in electronic format, no later than the following March and may be provided directly from the Partner or through a third party. The data will be used by EPA only for program evaluation purposes and will be closely controlled. If requested under the Freedom of Information Act (FOIA), EPA will argue that the data is exempt.

Any information used will be masked by EPA so as to protect the confidentiality of the Partner;

- notify EPA of a change in the designated responsible party or contacts for exit signs within 30 days.

### **Performance for Special Distinction**

In order to receive additional recognition and/or support from EPA for its efforts within the Partnership, the ENERGY STAR Partner may consider the following voluntary measures and should keep EPA informed on the progress of these efforts:

- consider energy efficiency improvements in company facilities and pursue the ENERGY STAR label for buildings;
- purchase ENERGY STAR labeled products. Revise the company purchasing or procurement specifications to include ENERGY STAR. Provide procurement officials' contact information to EPA for periodic updates and coordination. Circulate general ENERGY STAR labeled product information to employees for use when purchasing products for their homes;
- ensure the power management feature is enabled on all ENERGY STAR qualified monitors in use in company facilities, particularly upon installation and after service is performed;
- provide general information about the ENERGY STAR program to employees whose jobs are relevant to the development, marketing, sales, and service of current ENERGY STAR labeled product models;
- feature the ENERGY STAR label(s) on Partner Web site and in other promotional materials. If information concerning ENERGY STAR is provided on the Partner Web site as specified by the ENERGY STAR Web Linking Policy (this document can be found in the Partner Resources section on the ENERGY STAR Web site at [www.energystar.gov](http://www.energystar.gov)), EPA may provide links where appropriate to the Partner Web site;
- provide a simple plan to EPA outlining specific measures Partner plans to undertake beyond the program requirements listed above. By doing so, EPA may be able to coordinate, communicate, and/or promote Partner's activities, provide a EPA representative, or include news about the event in the ENERGY STAR newsletter, on the ENERGY STAR Web pages, etc. The plan may be as simple as providing a list of planned activities or planned milestones that Partner would like EPA to be aware of. For example, activities may include: (1) increase the availability of ENERGY STAR labeled products by converting the entire product line within two years to meet ENERGY STAR guidelines; (2) demonstrate the economic and environmental benefits of energy efficiency through special in-store displays twice a year; (3) provide information to users (via the Web site and user's manual) about energy-saving features and operating characteristics of ENERGY STAR qualified products, and (4) build awareness of the ENERGY STAR Partnership and brand identity by collaborating with EPA on one print advertorial and one live press event;
- provide quarterly, written updates to EPA as to the efforts undertaken by Partner to increase availability of ENERGY STAR qualified products, and to promote awareness of ENERGY STAR and its message.



# ENERGY STAR<sup>®</sup> Program Requirements for Exit Signs

## Eligibility Criteria

Below is the product specification (Version 2.0) for ENERGY STAR qualified exit signs. A product must meet all of the identified criteria if it is to be labeled as ENERGY STAR by its manufacturer.

1) **Definitions:** Below is a brief description of an exit sign and other terms as relevant to ENERGY STAR.

A. **Exit Sign:** An internally-illuminated sign that is permanently fixed in place and used to identify an exit from a building. A light source illuminates the sign or letters from within, and the background of the exit sign is not transparent. The exit sign is connected to only one source of power at a time (normal or emergency), and is designed to remain illuminated via an emergency power source upon failure of the normal power supply. The emergency power source is typically either a central back-up generator or an individual rechargeable battery included in each sign.

B. **Exit Sign Model:** For purpose of this agreement, an exit sign model is an exit sign in the configuration that is actually packaged and sold to end users under a unique model number or name. For exit sign models with an individual rechargeable battery, the battery charger shall be included as part of the exit sign model and shall be tested and qualified as a single product.

C. **Luminance:** The luminance of a surface is the luminous intensity in a given direction per unit area of that surface as viewed from that direction. Luminance is measured in candelas per square meter ( $\text{cd}/\text{m}^2$ ). An older unit for luminance is footlamberts ( $1 \text{ fL} = 3.43 \text{ cd}/\text{m}^2$ ).

D. **Luminance Contrast:** Luminance contrast quantifies the relative brightness of an object against its background. For exit signs, the relevant contrast is between the luminance of the letters and the luminance of the rest of the sign face (background). Luminance contrast can vary from zero to one. The closer the luminance contrast is to one, the more visible the letters are against the rest of the sign face. Luminance contrast is calculated as follows:

$$C = (L_{\text{greater}} - L_{\text{lesser}}) / L_{\text{greater}}$$

where C = luminance contrast

$L_{\text{greater}}$  = luminance of the legend or the background, whichever is the greater ( $\text{cd}/\text{m}^2$ )

$L_{\text{lesser}}$  = luminance of the legend or the background, whichever is the lesser ( $\text{cd}/\text{m}^2$ )

E. **NFPA:** The National Fire Protection Association (United States) develops the Life Safety Code for buildings that provides guidance for building design, construction, operation, and maintenance to protect occupants from fire, smoke, and fumes or similar emergencies. Many states and localities adopt this Life Safety Code into their own Building Code standards.

F. **Power Demand:** The amount of power required to continuously illuminate an exit sign model, measured in watts (W).

2) **Qualifying Products:** Any exit sign that meets the definition in Section 1A is eligible for the ENERGY STAR label. This agreement does not apply to exit sign retrofit kits.

- 3) Energy-Efficiency Specifications for Qualifying Products: Only those products listed in Section 2 that meet the criteria below in Table 1 may qualify as ENERGY STAR. In addition, Partner must include a statement in product materials that acknowledges luminance depreciation of any light source over time, and that code requirements for average luminance may not be maintained without lamp replacement at targeted intervals during the lifetime of the exit sign. A statement shall be included such as, “The light source in this exit sign will depreciate, which can lead to a light output level that is below current building code requirements. Lamps should be replaced at regular intervals, and when they are no longer functioning, to assure safety and visibility in the event of an emergency.”

<b>Table 1: Product Characteristics and Performance Specifications for Exit Signs (Version 2.0)</b>	
<b>Energy-Efficiency Characteristic</b>	<b>Performance Specification</b>
Input power demand	5 watts or less per face
<b>Visibility Characteristics</b>	<b>Performance Specification</b>
Letter size and letter spacing	The sign shall have the word “EXIT” or other appropriate wording in plain legible letters not less than 6 in. (15.2 cm) high with the principal strokes of letters not less than 3/4 in. (1.9 cm) wide. The word “EXIT” shall have letters of a width not less than 2 in. (5 cm) except for the letter “I”, and the minimum spacing between the letters shall be not less than 3/8 in. (1 cm). Signs larger than the minimum established in this paragraph shall have letter widths, strokes, and spacing in proportion to their height. <sup>1</sup>
Luminance contrast	Greater than 0.8
Average luminance	Greater than 15 cd/m <sup>2</sup> measured at normal (0°) and 45° viewing angles.
Minimum luminance	Greater than 8.6 cd/m <sup>2</sup> measured at normal (0°) and 45° viewing angles
Maximum to minimum luminance	Less than 20:1 measured at normal (0°) and 45° viewing angles
<b>Reliability Characteristic</b>	<b>Specification</b>
Manufacturer warranty for defects in materials and manufacturing	Replacement of defective parts for 5 years from date of purchase

- 4) Test Criteria: Manufacturers are required to perform tests and self-certify those product models that meet the ENERGY STAR guidelines. To meet the specification, the exit sign model must be tested under the following conditions, all performance measurements and calculations must be completed as described herein, and all the results must comply with the requirements stated in the Eligibility Criteria.

#### **Conditions for testing**

Testing shall be conducted in clear (non-smoke) conditions.

All measurements shall be made in a stable ambient air temperature of 25°C ± 5°C.

All voltages shall be provided within ± 0.5% by a constant voltage power supply.

Prior to input power or photometric measurements, the exit sign model shall be operated at the rated input voltage for a period of 100 hours. In addition, exit sign model with an internal battery shall be operated from the battery for one-and-one-half hours, the minimum period of emergency operation specified in NFPA’s “Life Safety Code”<sup>2</sup>, and then recharged for the period specified by the sign manufacturer.

<sup>1</sup> As in current NFPA 101, *Life Safety Code*, 7-10.6.1.

<sup>2</sup> As in current NFPA 101, *Life Safety Code*, 7-9.2.1.

All of the light sources in the sign must produce light throughout the first 100 hours of operation, before any measurements are taken, in order to meet the requirements of this specification.

### **Input power measurement**

The input power of the exit sign model in its entirety shall be measured with an appropriate True RMS Watt Meter at the rated input voltage which represents normal operation. For an exit sign model that includes a battery, the battery circuit shall be connected and the battery fully charged before any measurements are made.

### **Photometric measurements**

Each of the photometric characteristics of the sign shall be measured at three voltages:

- The rated input voltage which represents normal operation.
- A voltage corresponding to the minimum voltage provided either by the internal battery or a remote emergency power source after one minute of operation, as applicable.
- A voltage corresponding to the minimum voltage provided by the internal battery after the marked rated operating time or at 87.5% of the rated emergency input voltage for signs intended to be connected to a remote emergency power source. The level of illumination of the exit sign shall be permitted to decline to 60 percent of the initial illumination level (specified in Section 3 of the Eligibility Criteria) at the end of the emergency lighting time duration.

All measurements shall be taken with less than 0.01 footcandles of external illumination on the face of the exit sign model.

The luminances shall be measured from two viewing angles: 1) from normal (0°) to the face of the exit sign, and 2) from 45° to the face of the exit sign.

### **Luminance measurement positions**

The positions where the luminances for the legend and background of the exit sign are to be measured are shown below.<sup>3</sup> For instances in which exit sign model has a directional indicator, the positions where the luminances for the directional indicator and its background are to be measured are also shown below.<sup>4</sup>

---

<sup>3</sup> "Measurement of exit sign luminance" in NFPA 101, *Life Safety Code*, Figure A-7-10.6.3

<sup>4</sup> Found in Figure 40.9 "Directional indicator luminance measurement points" in UL 924, *Standard for Safety: Emergency Lighting and Power Equipment*, May 9, 1995.

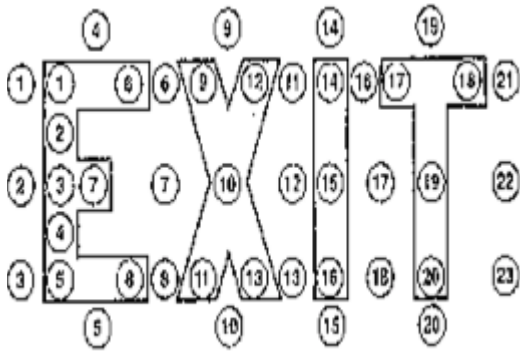

### Measurement of exit sign luminance

The luminances for each numbered position in the legend and directional indicator shall be measured over a circular area as large as possible while maintaining at least a 1.6 mm distance between the perimeter of the circular area and the adjacent border. The positions for measuring the luminances of the background shall lie within 25.4 mm of the legend and directional indicator but no closer than 1.6 mm to the border.

### Luminance calculations

Average luminance of the legend or background of the legend, whichever is higher, and where applicable, the directional indicator or its background, whichever is higher. For each, the mean of the luminances of all the positions measured.

*Luminance contrast ratio:*

$$\text{Contrast} = \frac{L_g - L_e}{L_g}$$

Where  $L_g$  is the greater luminance and  $L_e$  is the lesser luminance, either the variable  $L_g$  or  $L_e$  may represent the legend or directional indicator, and the remaining variable shall represent the respective background.

Minimum luminance of the legend or background of the legend, whichever is higher, and where applicable, the directional indicator and its background, whichever is higher. For each, the lowest luminance of all the points measured.

Luminance uniformity of the legend or background of the legend, whichever is higher, and where applicable, the directional indicator and its background, whichever is higher. For each, the ratio of the highest luminance of any position measured to the lowest luminance of any position measured.

- 5) Effective Date: The date that manufacturers may begin to qualify products as ENERGY STAR will be defined as the *effective date* of the agreement. The ENERGY STAR Exit Sign (Version 2.0) specification is effective immediately.
- 6) Future Specification Revisions: ENERGY STAR reserves the right to change the specification should technological and/or market changes affect its usefulness to consumers, industry, or the environment. In keeping with current policy, revisions to the specification are arrived at through industry discussions.

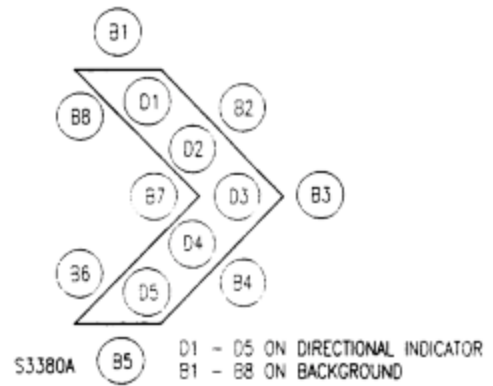

### Measurement of directional indicator