

EPA's ENERGY STAR Qualified Products Exchange (QPX)

XML Transaction System

09/01/2021

This document contains technical information regarding the XML Transaction System and serves as a resource for end-user development efforts.

CONTENTS

Purpose3

Introduction3

System Maintenance and Downtime3

Authentication Process3

Submission Process4

 Diagram of Submission Lifecycle.....4

 Type and Reason for Transaction.....6

 UPC Code Requirements7

 Associating Multiple Models with a Common Certification.....7

 Tested Model Name and Tested Model Number.....9

 Specification Revision Impacts10

Testing Process11

 How to Submit a Test Submission.....11

Validation Process12

Error Codes12

 Understanding Error Messages.....13

Unique Identifiers for Model, Certification, AND Family, and how they work.....16

 ENERGY_STAR_MODEL_IDENTIFIER16

 CERTIFICATION_ID16

 FAMILY_ID.....17

 Relational Model.....17

 Standards for Generating Unique Identifiers18

Web-Services WSDL Documentation20

 Overview20

 Service Naming Conventions20

 List of Current Services20

XSD Submission Schema Definition22

Glossary of Terms	23
Common Model Submittal Issues.....	24
Date Available on Market and Currently Available on Market	24
Product List and Product Finder Updates Schedule	24
Special Characters: ASCII and UTF-8 Standards	25
Transferring Certifications	25
QPX to Qualified Product List (QPL) and Product Finder Core Field Mapping	25
Support.....	25
Version Control	26

PURPOSE

The purpose of this document is to provide to certification bodies and other stakeholders the information necessary to interact with EPA's XML Transaction System for the ENERGY STAR Labeled Products Program. This document will describe system requirements that must be followed in order to interact with the transaction system.

INTRODUCTION

The Qualified Products Exchange (QPX) XML Transaction System is a fully-integrated, web-service that is based on the SOAP 1.1 Application Programming Interface (API). It utilizes XML and XSD standards to facilitate the communication of product certification data for ENERGY STAR between Certification Bodies (CBs) and EPA.

SYSTEM MAINTENANCE AND DOWNTIME

Please be advised, the QPX XML Transaction System has scheduled maintenance every Sunday evening from 8:00 PM ET to 12:00AM ET. Please do not plan to transmit data during this time.

AUTHENTICATION PROCESS

The authentication process for the QPX XML Transaction System uses the same credentials that partners have been using to access My ENERGY STAR Account ([MESA](#)). It includes the following fields in the SOAP 1.1 Authentication wrapper¹:

Field Name	Description
Authentication_UserName	Enter the user's MESA User Name
Authentication_Password	Enter the user's MESA Password
Certification_Body_EPA_Issued_Organization_Id	Enter your organization's CBO_ID. If you do not know your CBO_ID, please check MESA or contact Certification@energystar.gov

Table 1 lists the authentication fields that are required in the authentication wrapper of the SOAP 1.1 message protocol.

¹Authentication must occur for each submission, not each transaction since multiple models of the same product category can be submitted within a single submission.

SUBMISSION PROCESS

In order to submit certification data to the QPX XML Transaction System, users must have that data in Extensible-Markup Language (XML) format and that data must be in accordance with the Web Service Definition Language (WSDL)² file that is hosted at this location: <https://esws.energystar.gov/DataServices/servlet/webservices?ver=1.1&wsdlxml>. This file contains the services for which product information can be received and the standards to which the submission must adhere in order for a submission to be successful.

DIAGRAM OF SUBMISSION LIFECYCLE

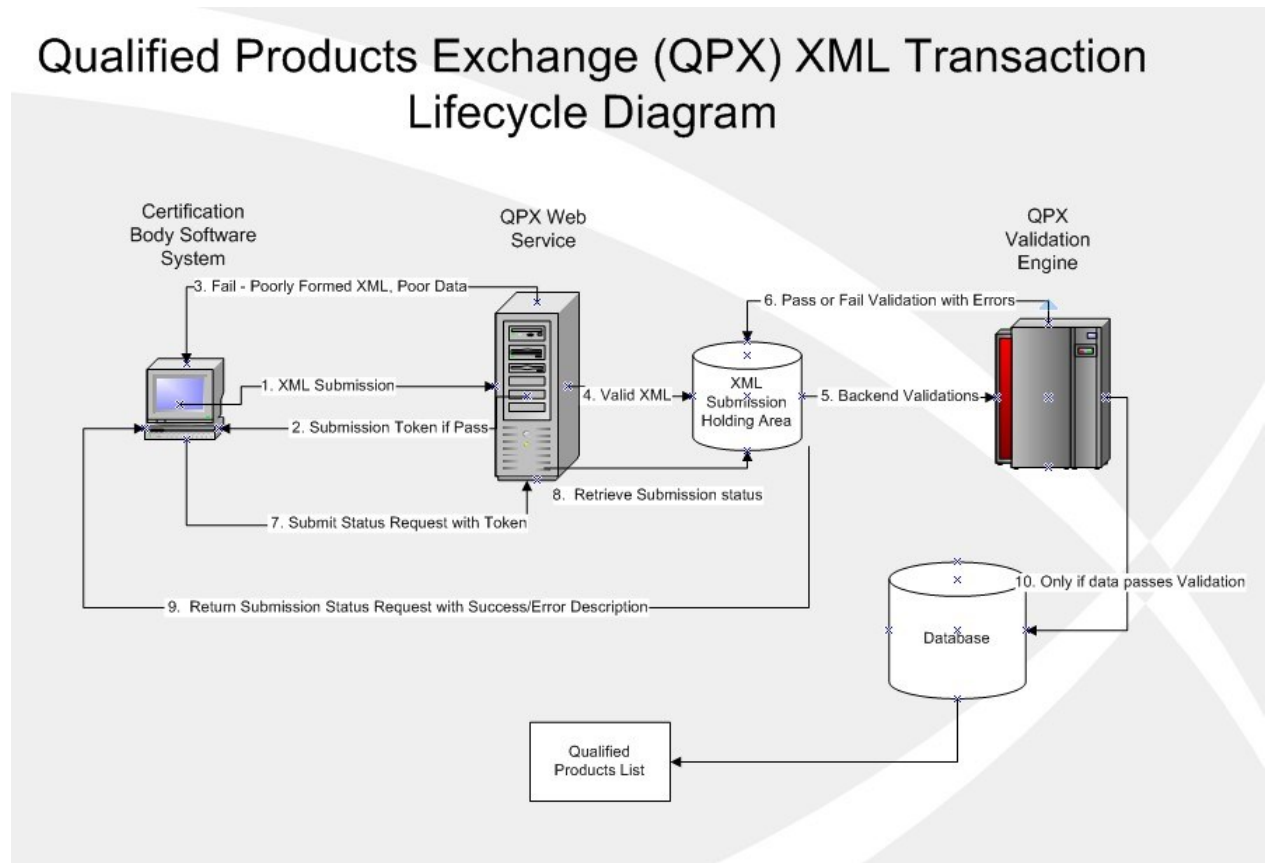

Figure 1 above depicts the transaction lifecycle of the ENERGY STAR QPX XML Transaction System. The system on the left-hand is an end-user client that will interact with the QPX web-service via the SOAP 1.1 protocol.

² For more information on the WSDL file, please visit the Web-services section of this document.

Process as depicted in Figure 1:

1. Certification bodies use their software to send their XML product data file to ENERGY STAR's web-service.
2. Upon a successful submission which has ONLY passed front-end, XML-schema validation, a submission token, which uniquely identifies a submission, will be returned. CBs must store this token for use later in the process.
3. If front-end validation fails, a response will be returned with either the failed data quality validations or a blanket error statement for poorly formed XML. If poorly formed, CBs should consult a 3rd-party XML validation tool to help validate the XML structure.
4. If front-end validation passes, the XML file will be transferred to a holding area where it will be queued for backend validation. Backend validation entails pulling information from the live database and running comparisons, as well as other validations listed in the Validation Process section of the Technical Documentation.
5. The QPX processing engine will validate information associated with each submission and test the data for accuracy compared to the data stored in the live database.
6. Upon completion of validation, a success or failure along with any associated errors for each model within the submission will be returned to the holding area.
7. Using the Submission Token, which uniquely identifies each submission, users can submit a request through the web-service for the status of that submission.
8. The web-service will retrieve the status of the submission with related error or success information.
9. The submission status request will be returned to the user.
10. If the data passes front and backend validation, it will then be stored in the database for use in reporting.

TYPE AND REASON FOR TRANSACTION

Below is a table that details the specific usage of these enumerated fields and how they should be properly maintained to ensure successful submissions. For instance, certain types of transactions can only have certain reasons, and vice-versa. If these fields do not match up, they will not pass back-end validation.

Type of Transaction	Reason For Transaction	Validation Rules
Initial Certification	<ul style="list-style-type: none"> Product Meets ENERGY STAR Requirements 	Model must not exist in live database for matching (CB_OID ³ , product type, ESUM_ID ⁴ and specification version or web service).
Modification⁵	<ul style="list-style-type: none"> Added Model Name/Number Removed Model Name/Number Changed Model Name/Number Changed Data Rerated Products Other (If Other, List in Notes Field) 	Model must exist in ENERGY STAR database for matching CB_OID, product type, ESUM_ID and specification version or web service. The last transaction type may not be Certification Withdrawn. In the case of multiple modifications, choose the most applicable reason for transaction.
Certification Withdrawn	<ul style="list-style-type: none"> No Longer Available Manufacturer Voluntary Withdrawal Delisted - Issue with Partnership Disqualified Product - Failed Testing Other (If Other, List in Notes Field) 	Model must exist in ENERGY STAR database for matching CB_OID, product type, ESUM_ID and specification version or web service. Model may not be subsequently submitted with the transaction type of Modification. Model may be resubmitted with a different Certification Withdrawn transaction type.

³ CB_OID is the Certification Body's Organization Identification number.

⁴ ESUM_ID is short for ENERGY_STAR_MODEL_IDENTIFIER which occurs frequently in this document. This sequence is a unique value that is expected to be generated by certification body software following the guidelines listed in the Unique Identifiers section of this document.

⁵ Modifications work by 'delete and replace' method since this is the most straightforward way of providing developers this functionality. The 'delete and replace' method requires you to take the same exact file, modify the fields that you want to modify, and resubmit. At a minimum, the new submission must have the same CB_OID, ESUM_ID, CERT_ID, and FAM_ID (if applicable) as the previous submittal in order to update the existing record.

<p>Recertification</p>	<ul style="list-style-type: none"> • Product Meets ENERGY STAR Requirements • Other (If Other, List in Notes Field) 	<p>Model must exist in ENERGY STAR database for matching CB_OID, product type, ESUM_ID and specification version or web service. Model must have had the transaction type Certification Withdrawn prior to submission with the transaction type of Recertification.</p>
<p>Registration</p>	<ul style="list-style-type: none"> • Included in Verification Testing Pool 	<p>Model must not exist in live DB for matching (CB_OID, product type, ESUM_ID and specification version or web service).</p>

Table 2 above depicts the Type and Reason for Transaction combinations and their validation rules that must be followed in order to have a successful back-end validation.

TYPE OF TRANSACTION: MODIFICATION - GUIDANCE

Modifications work by a ‘delete and replace’ method, and is the most straightforward way of providing developers this functionality.

The ‘delete and replace’ method requires that users take the same exact file, modify the fields that need to be modified, and then resubmit. As long as it has the same ESUM_ID the new submission data will replace the old data.

In the event of multiple modifications to a submission, please choose the most applicable type of modification.

TYPE OF TRANSACTION: CERTIFICATION WITHDRAWN - GUIDANCE

All transaction types are ‘delete and replace’ methods and all updates to any existing product require the full XML submission file in order to pass schema validation. Provide these data as well as the correct ESUM_ID to properly withdraw a certification.

UPC CODE REQUIREMENTS

UPC fields should be provided for all product categories submitted by QPX when they are available in the UPC code field. All UPC codes associated with the certification record should be submitted. In the case of highly configurable models covered by one certification, the UPC codes submitted may be a subset of all codes that are most frequently used in online products listings. While there is no limit to the number of UPC codes that may be submitted, only up to 250 codes will display on datasets that are configured to show one certification record per row. Note that the additional model information field should no longer be used to share UPC code information. While that field may still be populated with

other identifiers such as retail SKUs, all UPC code information should be submitted via the UPC code specific field.

The following fields are relevant for submitting the UPC codes that correspond to all the models for a given ESUM_ID.

- Universal Product Code (UPC) – This field allows CBs to include the UPC codes associated with the certified model. There is no limit to the number of UPC codes that may be submitted. CBs are not required to list every possible UPC code and should focus on codes that will appear in online product listings. This field is available for all products but will only be required for the web services associated with the products listed below. This code will need to be submitted as a string of digits. If not available, the UPC field needs to be left blank and the “Reason for Not Providing UPC Code” needs to be submitted for required product web services
- Reason for Not Providing UPC Code – There are select reasons that may be provided for not including a UPC code for the web services below. These reasons include: UPC Code Not Yet Assigned - CB Will Provide Later; UPC Code Not Yet Assigned - Partner Will Provide Later; No UPC Code Provided - Custom or Commercial Product; UPC Code Is Also Associated with Models Not Certified as ENERGY STAR (this is rare and only occurs if UPC codes are recycled for models not certified as ENERGY STAR); and No UPC Code Provided - Other Reason (for example the product is not sold at retail). If Other Reason is submitted, the system will require the “Other Reason for Not Providing UPC Code” to also be submitted. If the reason for not providing is that the CB will provide later, it is EPA's expectation that the UPC code be provided no later than when the product will be available for sale. It is not EPA's intention that partners obtain UPC codes solely for the purposes of the ENERGY STAR program. If a UPC code will not be obtained for the model, include that in this field and/or the other reason field.
- Other Reason for Not Providing UPC Code – This reason needs to be explained by the CB if “No UPC Code Provided – Other Reason” is specified in the previous field.

While these fields may appear optional in the XML schema, they are required for the web services associated with the products listed below per the field descriptions. Submissions that do not follow these rules will not be accepted by the EPA system during the backend validation routine performed after passing the XML schema validation step.

CBs may use the UPC code field to update existing certifications and should work with ENERGY STAR partners to update this information upon request. Note that there is a companion system for partners to submit UPC information directly to EPA for certifications. Partners are able to choose the CB-system or EPA-direct system for providing UPCs associated with existing certifications. UPCs provided directly to EPA by partners will supersede any CB-submitted UPC data.

Product Categories with Web Services Requiring UPC codes:

- Audio Video
- Ceiling Fans
- Clothes Washers
- Clothes Dryers
- Computers
- Connected Thermostats
- Dehumidifiers

- Dishwashers
- Electric Vehicle Supply Equipment
- Freezers
- Imaging
- Lamps
- Luminaires
- Monitors
- Pool Pumps
- Refrigerators
- Room Air Conditioners
- Room Air Cleaners
- Vent Fans
- Telephony
- Televisions
- Water Coolers

ASSOCIATING MULTIPLE MODELS WITH A COMMON CERTIFICATION

The QPX XML Transaction System allows additional models to be reported that have differing product attribute characteristics. To report models in this manner, each additional model needs to have a separate and unique ENERGY_STAR_MODEL_IDENTIFIER (ESUM_ID) and corresponding

CERTIFICATION_ID and FAMILY_ID⁶ that are the same. Additional models submitted in this manner will be displayed as unique rows on the Qualified Product List (QPL).

The system supports reporting additional models by using the Additional Model Name, Additional Model Number, and Additional Identifying Information fields. This allows for the listing of multiple additional models that are part of the same certification where performance characteristics are identical. It is important to note that there should not be duplicate listings of the same model across different certifications with varying performance characteristics. The additional models may be identified by multiple sets of a model name and/or model number and/or additional identifying information, such as SKU or retailer number. Each uniquely identified additional model name/number/identifier set must be listed as a separate entry within this field and must not be a comma-separated list. Please note that for reporting purposes, these models will be associated with identical performance data and will always be associated with the Model Name/Model Number listed in the submission.

The use of wildcards in model information is allowed, but should be minimized to facilitate matching of models on the EPA website with models sold in retail channels. The model number included in the model number field should be a model number unless it uses a wildcard that can be replaced by any digit or letter and still accurately capture what is covered by the certification. Whether or not a wildcard is used in the model number, the additional model numbers field should be used to include all other ENERGY STAR model numbers covered by the certification, ideally without use of wildcards.

If wildcards are used, only the asterisk symbol (*) should be used to represent a letter and only the number symbol (#) be used to represent a digit. Please note that the letters X and Y and any other numbers or symbols should not be used as wildcards since they may actually be parts of a model number. Since EPA product lists are machine readable, describing an alternate system for wildcards is not feasible.⁷

Note that for lamps and luminaires, the following features (as applicable) should be used to establish separate and unique ESUM_IDs even if all variations pass and thus could be represented by a wildcard. If wildcards for other features are used within an ESUM_ID, the variation expected to have the greatest difficulty meeting the performance requirements should be reported as the representative model.

- Series
- Recessed Downlight Aperture Size⁸
- Envelope Shape (e.g., ST19)
- Lamp Base (e.g., ANSI E26, GU24, etc.)⁹
- Reported Light Output or Reported Input Power¹⁰
- Color Rendering Index¹¹
- Correlated Color Temperature¹²
- Beam Angle or Beam Description (e.g. SP, NFL, FL)
- Dimmable or Non-Dimmable

⁶ Only if model is in a program that supports product families.

⁷ Limitations on use of wildcards in submissions to EPA do not apply to decorative light strings since EPA does not publish a list of certified model numbers for consumers.

⁸ For example, downlights with 6" and 8" aperture size should appear on separate rows of the QPL.

⁹ For example, E26-based and GU24-based models should appear on separate rows of the QPL.

¹⁰ For example, 800 lumen (9W) and 1,600 lumen (18W) models should appear on separate rows of the QPL.

¹¹ For example, 80- and 90-CRI models should appear on separate rows of the QPL.

¹² For example, 2700K and 3500K models should appear on separate rows of the QPL.

The additional models represented should only be those models available for purchase at the time the certification is marked as available. CBs may submit a modification to the submission to add or remove additional models as they become available or unavailable.

If there are more than 150 additional models representing configurations within the same certification, submission to EPA should be split into multiple ESUM_IDs under the same CERT_ID. This ensures that the ‘additional models’ field in the certified dataset does not exceed Excel limitations. The certifications should be split in a way that meaningfully differentiates the models for consumers.

If the model number lists a discrete number of identifiers in positions that define one of the lighting features listed above, or if not all of the options are covered by the certification, additional models options may also be submitted using a bracketed approach. In this case, the different options for the model number should be contained in bracket, with different variations separated by the pipe symbol, in the position where the wildcard symbols would have occurred. For example, in the case of model number ABC*, the additional models ABCb, ABCs, ABCf, ABCss covered by a single certification could be submitted as ABC[b|s|f|ss].

Additional Models Transaction Cases	Description	Type/Reason for Transaction	Requirements
Case 1: Adding Additional Model and/or Identifying Information as a stand-alone model for reporting	Additional Model has differing product attribute characteristics or Additional Models exceed 150	Initial Certification: Product Meets ENERGY STAR Requirements	NEW ESUM_ID ⁸ must be submitted along with the SAME CERT_ID and FAM_ID if applicable.
Case 2: Adding Additional Model and/or Identifying Information	Additional Model has identical product attribute characteristics as first model	Modification: Added Model Name/Number	The complete list of all additional models sets must be included in every submission.

Table 3 above depicts 2 cases for submitting additional models and how the system handles them.

Case 1 above represents new functionality that allows reporting additional models as unique models under the same certification and within the same family (if applicable). These models must have unique ENERGY_STAR_MODEL_IDENTIFIERS and the same CERTIFICATION_ID in order to be associated with other related models.

Case 2 above represents the traditional method of reporting Additional Models maintained in the ‘Core’ XSD file referenced in the WSDL, which comprises all the fields that are similar across product categories such as Model Name, Model Number, etc. When adding or removing Additional Models using this method, use Modification as the Type of Transaction.

⁸ Refer to glossary of terms for more information on these values and the section on Unique Identifiers

TESTED MODEL NAME AND TESTED MODEL NUMBER

For registered products where it is not possible to determine the exact model name and model number tested, CBs should indicate “Not available – model registered” in the fields for Tested Model Name and Tested Model Number. Note, as of March 31, 2011, CBs should not be submitting any initial certifications as “Registration” unless specifically directed by EPA.

SPECIFICATION REVISION IMPACTS

EPA periodically [revises specifications](#) for ENERGY STAR products to keep pace with the evolution among leading products and continue to effectively differentiate efficient products for consumers. Revisions are categorized as either a major revision (e.g. 2.0) or a minor revision (e.g. 2.1) and the current status of each revision can be found at www.energystar.gov/revisedspecs.

MAJOR SPECIFICATION REVISION

For major revisions, EPA will always release a new web service to accommodate possible scope, test method, unit of measure, and added/removed data requirement changes between the previous and upcoming specifications. CBs will be notified of a draft data requirements review period and web service testing period. Once a new web service's test phase has ended, models submitted to the new web service will typically automatically be added to the product list and product finder.

All models meeting the revised ENERGY STAR requirements for certification must be submitted to the new web service as Initial Certification, confirming for EPA the models meet the new requirements. ENERGY_STAR_MODEL_IDENTIFIERS and CERTIFICATION_ID should remain the same for previously certified models when submitted to a new web service.

When a current and an upcoming specification simultaneously exist, partners may elect to only certify models to the upcoming specification. A model may be certified to both the current and upcoming specification at the same time and will appear on the certified product list twice. EPA does not filter out duplicates between versions since characteristics or test method changes may change data for the same model from one specification version to the next version. EPA prefers, but does not require, the older certification is withdrawn to minimize duplicate listings and consumer confusion.

MINOR SPECIFICATION REVISION

For minor specification revisions, models do not need to be resubmitted. However, changes in performance information related to specification updates, such as DOE test method changes, may require modifications for the submittal of additional information. CBs will be notified when additional information may be required for existing submissions.

CESSATION DATE

The cessation date typically falls 4 - 5 months prior to an updated specification's effective date. On the cessation date, CBs must cease initial certification of models to the older specification. The exact

cessation date is provided in cover memos for each finalized specification revision, and EPA notifies CBs prior to the cessation date.

After the cessation date has passed, CBs must notify EPA within one business day of the cessation date if initial certifications have not yet been uploaded, or the submissions may be permanently blocked from upload.

The cessation date validation will only reject Type of Transaction: Initial Certification and Type of Transaction: Registration. CBs may continue to submit modified data after the cessation date has passed and prior to the new specification's effective date.

EFFECTIVE DATE

For major specifications, the web service associated to the previous specification version will no longer allow any submissions beginning the day the new specification is effective. Only models submitted to the web service associated with the new specification version will be publicly displayed on the product lists and product finders. CBs are encouraged to work with partners to submit models for upcoming specifications in advance of the effective date to minimize disruption to model listings.

TESTING PROCESS

HOW TO SUBMIT A TEST SUBMISSION

The CB will create a valid XML file for the product to be submitted. A valid file is both well-formed (all open tags have a corresponding close tag) and conforms to the schema (which is provided in the WSDL). For example, to submit a Geothermal Heat Pumps test file, the XML will contain a <core_submission> block which contains the following elements for all products:

1. username - same as the one used to login to MESA
2. password - same as the one used to login to MESA
3. Certification Body Organization ID - this is the same Organization ID that is associated with your organization in MESA (it is a number).
4. Test Submission indicator - **mark this as "Yes" to indicate a test submission**. A test submission is one that the system will check for errors, but not store in the live database tables. It is recommended to try a test submission first in order to discover any errors before performing a regular submission. Also, a faster response is expected with the test submission because it will not be delayed by other various database jobs.

The test submission also has a block called <core_product_data>. These are fields that are common to all product types. The core block is followed by all the product-specific fields, such as <Tested_Value_EER_Rating>, which is a field in the Geothermal Heat Pumps submission container. The CB must ensure that all the required fields have values.

QPX will respond with either a generic error message or a detailed response XML (the difference is explained below in the validation process section). In the case of the latter, **CBs must take care to store the submission token!** This is the only way for a CB to track the success or failure of a submission after it has been processed.

VALIDATION PROCESS

Validation within the QPX System is a multi-step process. Due to the nature of the system design, there are strict front-end validations that are embedded within the XML Schema Definition (XSD) file that ensures only properly formed data sets will be submitted to the system. Once this data is received by the server, it is sent to a holding area where the QPX processing engine will validate the information. This process can take anywhere from a few seconds to 10 minutes depending on the server load.

There are **THREE** types of failing submissions:

Type of Failed XML Submission	Description	Action
Poorly formed XML structure	The submitted XML file does not match up correctly with the XSD schema definition file. A detailed error response message will be returned with the lines in the XML file that failed schema validation.	Please evaluate the structure of your XML file by using a 3 rd -party XML validation tool to help identify errors in the submission.
Poor data quality	Data is not meeting the standards imposed by the XSD file. I.E. if certain data are not in the correct format or breach the length constraints for certain fields.	A detailed error response message will be returned with the lines in the XML file that failed data quality validation. ⁹
Submission failed back-end validation	Data is not passing back-end validation checks performed by QPX processing.	Error codes will be returned as a response to the Submit_Status_Request service listed in the Web-Services WSDL section of this document.

Table 4 above depicts the 3 types of failed 'front-end' XML/XSD validation that occurs when the XML transmission is submitted against the web-service. If a submission passes front-end validation, it still has to pass back-end QPX processing validation in order to be considered successful.

ERROR CODES

The following table lists the current error codes that will be received in the message response either during initial submission or upon submission through the Submit_Status_Request_For_Submission service which is described in the Web-Services section of this document.

⁹ It is likely that certification body software using .NET libraries and Java libraries will not allow the data to be sent across the web unless it conforms to the XSD standards, and error messages will be generated by those libraries locally.

UNDERSTANDING ERROR MESSAGES

There are a number of errors that may occur with a submission:

- XML with correct structure, but wrong authentication credentials or organization ID. Please refer to the Error Code table (Table 5) below as a reference.
- XML with correct structure and authentication, but inconsistent with schema. This might occur if, for example, a date field is filled out with text data, or if a required field is left blank. Such errors will be indicated by the code 99999. The <message> field in the response XML will contain a list of all the locations in the submission file where errors were detected. You can use this message to fix your data and then attempt to resubmit.
- If none of the errors described above were encountered, the response XML will return a code 0 (successful authentication and schema validation). However, even though the submission passed authentication and schema validation, it will still need to be processed by the database. **After five to ten minutes**, CBs will be able to submit a status request XML using the submission token to the Submit_Status_Request web-service that is detailed in the Web-services section of this document. The service will then respond with the status of the back-end validation for each of the transactions within the submission and the results of back-end processing. For example, the service will check to make sure all laboratory and manufacturer ID's are valid and point to appropriate organizations in the database.

Error Code	Error Message
1002	Invalid username.
1003	Invalid password.
1004	Invalid Organization ID.
1005	User used to authenticate is inactive with ENERGY STAR.
1006	User is not associated with Specified Certification Body.
1007	Submission Token Provided cannot be null or empty string.
1008	Submission Token Provided is not valid. Please check your Submission Token and retry.
1009	Submission Token Provided is not owned by Certification Body listed.
1010	This Submission is still in queue of processing. Please check back the status after sometime.
ESQPX-5001	ENERGY STAR Manufacturing Partner ID "^^PARAM1^^" listed is not in ENERGY STAR database.

ESQPX-5002	ENERGY STAR Manufacturing Partner ID "^^PARAM1^^" listed is not associated with the program "^^PARAM2^^" in ENERGY STAR database.
ESQPX-5003	Laboratory's EPA-issued Organization ID "^^PARAM1^^" listed is not in ENERGY STAR database.
ESQPX-5004	Laboratory's EPA-issued Organization ID "^^PARAM1^^" listed is not associated with the program "^^PARAM2^^" in ENERGY STAR database.
ESQPX-5005	Product Type "^^PARAM1^^" defined for the product is not a valid product type accepted by ENERGY STAR.
ESQPX-5006	Type of Transaction "^^PARAM1^^" listed for the product is invalid.
ESQPX-5007	Reason for Transaction "^^PARAM1^^" listed for the product is invalid.
ESQPX-5008	Type of Transaction "^^PARAM1^^" and Reason for Transaction "^^PARAM2^^" is not the right combination.
ESQPX-5009	Product - "^^PARAM1^^", "^^PARAM2^^" having ENERGY STAR Model Identifier - "^^PARAM3^^" already exists and hence cannot be accepted with transaction type of "^^PARAM4^^".
ESQPX-5010	Product - "^^PARAM1^^", "^^PARAM2^^" having ENERGY STAR Model Identifier - "^^PARAM3^^" does not exist and hence cannot be accepted with type as "^^PARAM4^^".
ESQPX-5011	Date Certification Body Notified Partner of Model Certification "^^PARAM1^^" is not a valid date. Date must be in range 1/1/2011 to present.
ESQPX-5012	Date submitted for Date Tested "^^PARAM1^^" is not a valid date and must be within the last 20 years.
ESQPX-5013	Certification ID "^^PARAM1^^" and Family ID "^^PARAM2^^" do not meet validation criteria.
ESQPX-5014	Laboratory Contact for this Model is required.
ESQPX-5015	Laboratory's EPA-issued Organization ID is required.
ESQPX-5016	Currently Available in Market "^^PARAM1^^" must be set to "No" if the Date Available on Market is in future.

ESQPX-5017	Date Available on Market "^^PARAM1^^" must not be older than 20 years and not after four years in future.
ESQPX-5018	The only transaction type allowed for this model is "Certification Withdrawn" or "Recertification."
ESQPX-5019	Date Tested "^^PARAM1^^" cannot be a future date.
ESPQX-5020	The transaction type of Recertification is allowed only if the model was previously submitted as Certification Withdrawn.
ESPQX-5021	Transaction type ^^PARAM1^^ not allowed for ^^PARAM2^^ ^^PARAM3^^ ENERGY STAR Manufacturing Partner.
ESPQX-5022	The cessation date has passed for this specification version and initial certifications are no longer allowed.
ESPQX-5023	Product PD_ID ^^PARAM1^^ listed for ^^PARAM2^^ is invalid
ESPQX-5024	Market ^^PARAM1^^ listed for Model Number ^^PARAM2^^ is no longer valid
ESPQX-5025	ENERGY STAR Certification Body Organization may not have correct affiliation/standing with the Area of Recognition.
ESPQX-5026	ENERGY STAR Lighting Subcomponent organization ID {0} listed is not associated with the active Lighting Subcomponent program in the ENERGY STAR database.
ESPQX-5027	The partner ^^PARAM1^^ associated with the submission only sells products in Canada. The partner needs to notify EPA that they sell products in the United States.
ESPQX-5028	Universal Product Code or Reason for Explanation is required for this product category .
ESPQX-5029	[Universal Product Code] (UPC) is required; if UPC cannot be provided, the [Reason for Not Providing UPC Code] is required .
ESPQX-5030	[Other Reason for Not Providing UPC Code] is not allowed for[Reason for Not Providing UPC Code] enumeration's other than"No UPC code Provided - Other Reason" .

Table 5 above is a depiction of error codes that will be returned as the result of failed validations that are performed on the backend QPX Processing Engine.

UNIQUE IDENTIFIERS FOR MODEL, CERTIFICATION, AND FAMILY, AND HOW THEY WORK

The QPX XML Transaction System incorporates fields that help distinguish individual certifications as uniquely identifiable and can be associated to a group of additional models or a family of products. By capturing this information, EPA is able to enhance reports, such as the Qualified Products Lists (QPLs), by allowing additional models with differing product attribute characteristics to be displayed individually. By adding Family_ID, EPA is able to report on products associated with families.

Once ENERGY STAR unique identifiers are created and submitted, they **CANNOT** be altered. These identifiers are meant to be a 'one-time' generation and the system uses these sequences for identifying models, certifications, and families. The ENERGY_STAR_MODEL_IDENTIFIER shall remain permanent through the entire model life-cycle across all specification versions. CERTIFICATION_ID may be updated for an existing model. FAMILY_ID may be updated or added for an existing model.

ENERGY_STAR_MODEL_IDENTIFIER

The ENERGY_STAR_MODEL_IDENTIFIER is a unique sequence that users are required to generate for each model that has differing performance characteristics, and is reported as a single row of data on the Qualified Products lists (QPLs) (single record in the product finder tools). This unique sequence serves to distinguish each *model* within the QPX system.

It is important to note the permanency of this identifier as it shall remain the same for the unique model through *differing specification versions*. This allows EPA to track the life-cycle of a particular model.

The identifier will be publicly available for the purpose of tracking each model and should not include sensitive information, including but not limited to original equipment manufacturer (OEM) model information.

For more information on generating this value, please see Table 6 below on naming standards. This value is NOT optional.

CERTIFICATION_ID

The CERTIFICATION_ID is a unique sequence that users are required to generate for each individual *certification*. Certification_ID serves to distinguish one or more models with differing performance characteristics under a single certification in order to track models associated with that certification and is used by EPA to determine unique model counts for verification testing selection.

Certification ID will often match product family or basic models, as defined by an ENERGY STAR specification, and future model additions within the product family should use the same Certification ID. One or more ENERGY_STAR_MODEL_IDENTIFIERS may be associated with each unique CERTIFICATION_ID and Certification IDs can be applied across partners and private labeling models. Please see Table 6 below on naming standards. This value is NOT optional.

FAMILY_ID

The FAMILY_ID is a unique sequence that users may generate for products if they are certified as a product family or Department of Energy (DOE) Basic Model group. FAMILY_ID should be generated only when submitting models for ENERGY STAR specifications that permit product families. Please see Table 6 below on naming conventions. This value is optional but should be included for product family certifications.

RELATIONAL MODEL

Below is a depiction of the database model for the identifiers described above and their role within the QPX system and client-side systems.

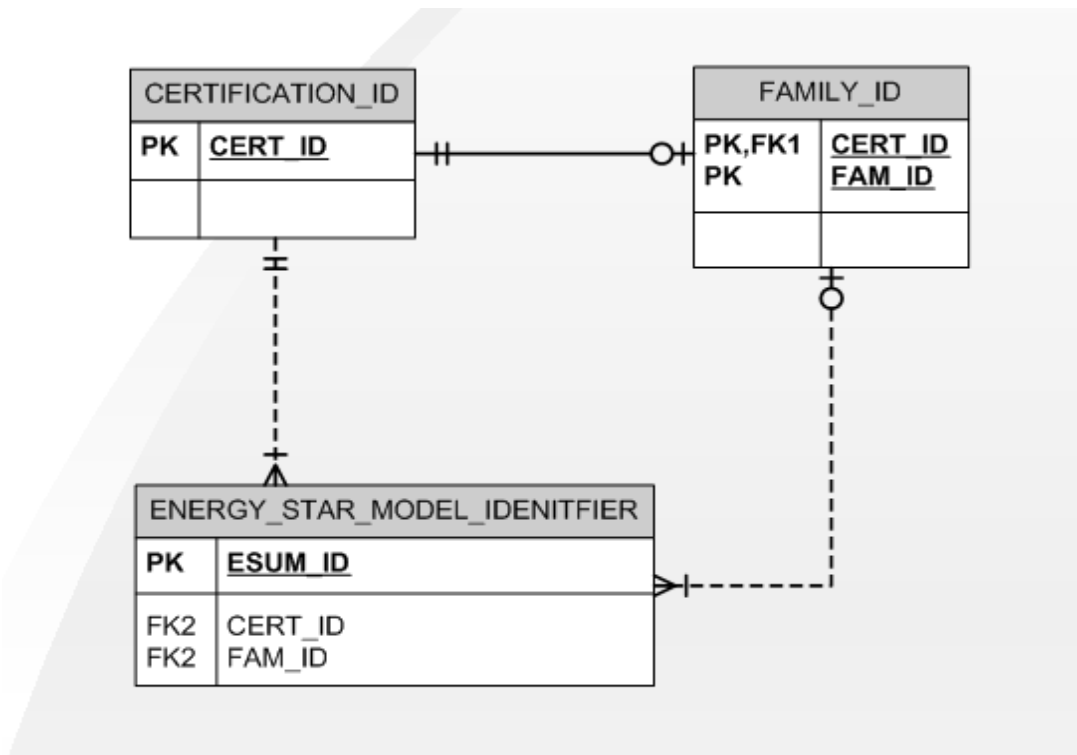

Figure 2 above is a depiction of the relationship between three unique identifiers that the QPX XML Transaction System uses to determine uniqueness of the individual model, certification, and family. Please refer to Table 6 below for a more detailed description.

RELATIONAL MODEL DESCRIPTION

The above diagram is a basic description of how the QPX XML Transaction System handles the relationship between these three values.

Field Name	Restrictions
ENERGY_STAR_MODEL_IDENTIFIER (ESUM_ID)	MUST have EXACTLY ONE CERTIFICATION_ID and ZERO or ONE FAMILY_ID. SHALL remain PERMANENT through entire model life-cycle across ALL specification versions for the unique model.
CERTIFICATION_ID (CERT_ID)	MUST have at LEAST ONE ESUM_ID and can have MANY ESUM_IDs. CERT_ID can have ZERO or ONE FAMILY_ID. NOT permanent through entire model life-cycle, can be updated if needed.
FAMILY_ID (FAM_ID)	MUST have at LEAST ONE ESUM_ID and can have MANY ESUM_IDs. FAM_ID MUST have ONE and only ONE CERT_ID NOT permanent through entire model life-cycle, can be updated, if needed.

Table 6 above depicts in detail the relationship that is described in Figure 2, as well as the modality between the three fields.

STANDARDS FOR GENERATING UNIQUE IDENTIFIERS

In the XML Transaction template for any product web-service, there will be three fields that will require the implementation of naming conventions. These fields are used as unique identifiers in the database and define individual models, families of models, and unique certifications. Once these unique identifiers are created and submitted, **they CANNOT be altered**. These identifiers are meant to be a ‘one-time’ generation and the system uses these sequences for identifying models, certifications, and families. In order to prevent two CBs from generating the same ID, EPA established the following standards:

Field Name	Standard
ENERGY_STAR_MODEL_IDENTIFIER	<p>ES_<ManufacturerOID>_<MODELNUMBER>_<MMDDYYYYH24MISS>_<randomnumber> 7-digit random. Please Note: Total Max length of this should not exceed 400 characters.</p> <p><ManufacturerOID> = Fill in Manufacturer EPA issues O_ID <MODELNUMBER> = Fill in Model Number of the product <MMDDYYYYH24MISS> = Create date time string in the format where MM= month number, DD - Day number, YYYY = Year number, H24 hours (0-23), MI minute number, SS seconds. This typically indicates the date of certification, but there are no validations performed on it. <randomnumber> = Enter a random number to make this identifier unique. Example: ES_0012321_ANPRC422_03282011223443_3141592</p> <p>Type: VARCHAR (400) Note: SHALL remain PERMANENT across ALL specification versions for the unique model.</p>

<p>CERTIFICATION_ID¹⁰</p>	<p>CER_<ManufacturerOID>_<MMDDYYYYH24MISS>_<randomnumber> 7-digit random. Please Note: Total Max length of this should not exceed 400 characters. <ManufacturerOID> = Fill in Manufacturer EPA issued O_ID <MMDDYYYYH24MISS> = Create date time string in the format where MM= month number, DD - Day number, YYYY = Year number, H24 hours (0-23), MI minute number, SS seconds. This typically indicates the date of certification, but there are no validations performed on it. <randomnumber> = Enter a 7 digit random number to make this identifier as unique. Example: CER_0012321_03282011223445_1414213</p> <p>Type: VARCHAR (400)</p>
<p>FAMILY_ID¹¹</p>	<p>FAM_ManufacturerOID>_<MMDDYYYYH24MISS>_<randomnumber> 7-digit random. Please Note: Total Max length of this should not exceed 400 characters. <ManufacturerOID> = Fill in Manufacturer EPA issued O_ID [[MMDDYYYYH24MISS]] = Create date time string in the format where MM= month number, DD - Day number, YYYY = Year number, H24 hours (0-23), MI minute number, SS seconds. This typically indicates the date of certification, but there are no validations performed on it. <randomnumber> = Enter a 7 digit random number to make this identifier as unique. Example: FAM_0012321_03282011223445_1984292</p> <p>Type: VARCHAR (400)</p>

Table 7 above depicts the standards and conventions for three unique identifiers that are required to be generated by end-users within their software solutions. These naming conventions should adhere to the above guidelines in order to prevent any data from being lost due to users generating duplicate IDs for different models.

¹⁰ The only difference in the standard for generating CERTIFICATION_ID and ENERGY_STAR_MODEL_IDENTIFIER is that CERTIFICATION_ID does NOT require <MODEL_NUMBER> and has a CER_ prefix.

¹¹ The only difference between generating CERTIFICATION_ID and FAMILY_ID is the prefix. This will allow developers to reuse code.

WEB-SERVICES WSDL DOCUMENTATION

OVERVIEW

The QPX XML Transaction System implements the **SOAP 1.1 protocol** for the transfer of product certification data through XML web-services. The WSDL file can be referenced here: <https://esws.energystar.gov/DataServices/servlet/webservices?ver=1.1&wsdlxml>.

SERVICE NAMING CONVENTIONS

Standardized naming conventions for services and namespaces are as follows:

Naming Convention	Example	Specifications Supported	Namespace
Submit_Product_1_x	Submit_Geothermal_Heat_pumps_3_x	3.1, 3.2, etc.	http://www.energystar.gov/schema/Geothermal_Heat_Pumps_3_x/

Table 8 above depicts the naming convention standard for web-services

In the above example, the web-service will always support minor specification changes and new web-services will only be created for major specification revisions, e.g. If there is a major revision to geothermal heat pumps (v4.0), this will require a new web-service.

LIST OF CURRENT SERVICES

Current web services are available at www.energystar.gov/qpx

PRODUCTS WEB-SERVICES

For a listing of products web-services and their status of development, testing, and live use, please bookmark www.energystar.gov/qpx and check for updates frequently or subscribe to RSS feeds for a particular service. This page also contains the data requirements for each web-service in a human-readable format, as well as sample XML files that developers may use for testing submissions.

Each service can handle one-to-many products in a submission as long as those submissions are within the same product specification. For any issues in communicating with these services please send an email to Certification@energystar.gov with QPX XML in the subject line and attach a compressed version of your XML submission file to assist our team in determining the issue.

SYSTEM WEB-SERVICES

The below table contains the web-services that are hosted on the QPX Submission WSDL file. These services are separate from the products services and require a separate and smaller set of data to be sent to the web-service.

System Web-service Name	Date Active	Testing	POC	Namespace	Description	Response Object
Submit_Status_Request_For_Submission	11/7/11	Yes	Certification@energystar.gov	http://www.energystar.gov/schemas/status/	Submit your submission token which is returned upon successful completion for a status update regarding your submitted data	Status_Response - returns manufacturer partner, model name, model number, unique identifier (ESUM), accepted or rejected, and error messages

Table 9 above lists active system web-services such as the Status_Request_For_Submission, which takes Submission-Token as a parameter and returns 'Status' of backend validations to the end-user.

XSD SUBMISSION SCHEMA DEFINITION

Below is a depiction of the SOAP 1.1 submission container and how that information is designed in the WSDL file. We are using Geothermal Heat Pumps (GHP) as an example.

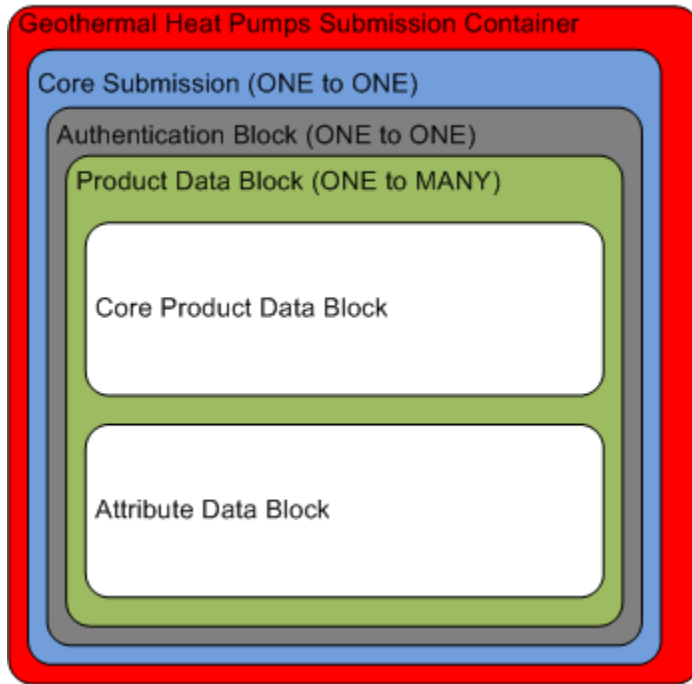

Figure 3 depicts the layout of the XML submission container and how data is structured within a submission through a products web-service.

Within the submission container, there is a second container named `Core_Submission`, which is a 1-1 relationship with regards to a single submission. Within this container is the authentication block, which is also a 1-1 relationship. Under this block is the Product Data Block, which can occur 1-Many times, allowing for the inclusion of multiple transactions for multiple models within the same product category, which in this case is Geothermal Heat Pumps. Core product data is a collection of fields that are universal across all products, such as model name and model number. Attribute Data block contains the product-specific fields that are unique to that product.

GLOSSARY OF TERMS

Below is a table listing frequently used terms and their corresponding descriptions.

Term	Description
CBs	Certification Bodies – organizations which are qualified to send product certification data to ENERGY STAR.
CERT_ID	Short for Certification_ID, which is a unique sequence that is to be generated by certification bodies that will uniquely identify a SINGLE certification within the QPX XML Transaction System.
ESUM_ID	Short for ENERGY_STAR_MODEL_IDENTIFIER, which is a unique sequence that is to be generated by certification bodies that will uniquely identify a SINGLE model within the QPX XML Transaction System.
FAM_ID	Short for Family_ID, which is a unique sequence that is to be generated by certification bodies that will uniquely identify a SINGLE family within the QPX XML Transaction System.
GHP	Geothermal Heat Pumps – the first product program to be supported by ENERGY STAR's QPX XML Transaction System under specification Version 3.1 Tier 3.
MESA	Short for My ENERGY STAR Account, which is a system that certification bodies can access and stands for My ENERGY STAR Account.
QPX	Qualified Products Exchange XML Transaction System – ENERGY STAR's new web-service system based on XML transmissions between ENERGY STAR's web-services and certification bodies software systems.
SOAP	Simple Object Access Protocol – a transmission protocol for web-services that allows communication between two services.
XML	Extensible-Markup Language – a language that describes data that can be transmitted across the web between two services.

Table 10 above is a glossary of terms that appear frequently within this document and their corresponding descriptions.

COMMON MODEL SUBMITTAL ISSUES

DATE AVAILABLE ON MARKET AND CURRENTLY AVAILABLE ON MARKET

Date Certification Body Notified Partner of Model Certification: This date should reflect the date that the CB notified the ENERGY STAR Manufacturing Partner of certification to the current major specification version. For example, if a model was certified to V1.2 on 1/1/2012 and the CB certified the model to V2.0 on 1/2/2013, then the Date CB Notified Partner of Model Certification should reflect the date the CB notified the partner of model certification under V2.0 or 1/2/2013.

Date Available on Market: Models will automatically display on or after the Date Available on Market has passed. EPA does not display models with a future date available to allow partners to certify models prior to public release.

Date Available on Market older than 20 years: The QPX validation automatically rejects models with a date available on market older than 20 years in the past from the date of submission. In the rare cases a model was available on the market over 20 years ago, CBs may submit a date 20 years prior to the date of submission.

Currently Available on Market: If a model is marked as Currently Available on Market is marked as "No," the model will not display on the Qualified Product List (QPL) or product finder tool. The Currently Available on Market field allows partners via their CBs to prevent models from publicly displaying.

For models with a date available in the future, EPA's system will automatically switch the Currently Available on Market flag to Yes after the Date Available on Market has passed. Note CBs must update their internal records to indicate Currently Available on Market is Yes or a future CB modification will switch the flag back to not available on market in EPA's system.

Certified models not currently available on the market: CBs should list date available as four years in the future, and CBs should work with the partner to update the market availability date as needed

VALID MARKETS FOR PRODUCTS

The enumerations included for "In What Markets Is this Model Sold?" may only include countries where EPA has international agreements for the specific product being submitted. For most products, this means that only the US and/or Canada are options for markets. For storm windows, the markets are limited even further to only the US. For the following select office equipment products, Japan and Taiwan may be included only if the products are also available in the US and/or Canada:

- Computers
- Imaging Equipment
- Displays
- Uninterruptible Power Supplies
- Computer Servers

For Computers and Imaging Equipment, Switzerland may be included only if the products are also available in the US and/or Canada.

Models only available in Japan may not be submitted via QPX since Japan has their own registration process. Models available in Switzerland and Taiwan may only be certified if also available in the US and/or Canada since those countries do not have their own process for registering certified models.

Note that since there are no longer agreements in place with the European Union, Australia, or New Zealand, any model marked as initial certification with Europe, Australia, or New Zealand as markets will not be accepted by our system.

PRODUCT LIST AND PRODUCT FINDER UPDATES SCHEDULE

Publicly available Qualified Product Lists (QPLs) and ENERGY STAR Product Finder Tools are updated as follows:

1. Models submitted with successful validation by 11:59 ET will appear on the product list and product finder tools the following day, including weekends and holidays.
2. Product lists, available at data.energystar.gov, are updated between 8AM and 11AM ET daily.
3. Product finders are updated within an hour of product list updates. All product finders will have updated data by 12 PM ET.

SPECIAL CHARACTERS: ASCII AND UTF-8 STANDARDS

EPA's QPX system allows submittal of characters per the ASCII standard and will indicate successful submission for the data. However, EPA's database only stores characters per the UTF-8 standard, a more limited set of characters. While CBs can submit special characters, such as copyright, trademark, etc. without validation errors, EPA strongly recommends only submitting UTF-8-allowable characters as non-conforming characters will appear as long strings of question marks in product lists.

TRANSFERRING CERTIFICATIONS

Transferring products between CBs: New CB should submit models as initial certification since the new CB will have to independently certify the products. Old CB should withdraw certification as the CB is no longer responsible for verifying claims made by the partner.

Transferring products between partners (e.g. brand owner issues): CB should modify existing submission with updated ENERGY STAR product brand owner name, brand name, and any additional changes. Note the ENERGY_STAR_MODEL_IDENTIFIER cannot be modified and likely will no long conform to schema requirements for creating a new ENERGY_STAR_MODEL_IDENTIFIER. This is acceptable for transferring model records.

QPX TO QUALIFIED PRODUCT LIST (QPL) AND PRODUCT FINDER CORE FIELD MAPPING¹²

Data requirement fields CBs provide to EPA	Brand Name	Model Name	Model Number	Additional Model Name	Additional Model Number	Additional Identifying Information
---	-------------------	-------------------	---------------------	------------------------------	--------------------------------	---

Product list fields	Brand Name	Model Name	Model Number	Additional Model Information
Product finder tool: search page	Brand Name + Model Name		<i>Appears in search results: Model Number, Additional Model Information</i>	
Product finder tool: details and compare pages	Brand Name + Model Name + Model Number			<i>Appears in second tab: Additional Model Information</i>

Table 12 above provides mapping of several core fields and how the information is typically combined and displayed publicly.

SUPPORT

CBs are encouraged to subscribe to the XML Web Services Submission Process RSS feeds to receive notification on any web service changes. RSS feeds can be found on the XML Web Services Submission Process at www.energystar.gov/qpx in the Data Requirements view for each web service or a full list can

¹² Appliances and lighting product categories may not include ENERGY STAR Partner, brand name or model name information in the table above within the product lists and product finders.

be found at the top of the XML Web Services Submission Process webpage under the link [RSS Feed on QPX Web Service Updates](#).

For questions or issues please contact Certification@energystar.gov with "QPX System" in the subject line.

VERSION CONTROL

Version History	Date	Description
Version 2.8	9/1/21	<ul style="list-style-type: none"> Included section on UPC code fields added to the core data.
Version 2.7	11/30/20	<ul style="list-style-type: none"> Further clarified wildcard requirements, to specify that each wildcard character should only represent a single letter or digit.
Version 2.6	2/13/20	<ul style="list-style-type: none"> Clarified requirements for reporting separate ESUM_IDs for lamps and luminaires.
Version 2.5	2/14/19	<ul style="list-style-type: none"> Clarified allowable enumerations for "In What Markets Is this Model Sold?". Added error codes for invalid market and PD_ID.
Version 2.4	1/5/16	<ul style="list-style-type: none"> Added specifications and guidance describing the use of sets to simplify and more clearly describe model numbers (e.g. 15C[AAA BBB])
Version 2.3	09/09/16	<ul style="list-style-type: none"> Added requirements for use of wildcards and limitations on number of additional models per unique certification. Removed references to the initial excel-based system. Clarified that the same model number should not be submitted under different ESUM_IDs.
Version 2.2	12/22/14	<ul style="list-style-type: none"> Updated and clarified web-services system requirements.
Version 2.1	7/24/12	<ul style="list-style-type: none"> Removed Web-service table as all updates and statuses on web- services can be accessed at: www.energystar.gov/qpx Please bookmark this page and check for updates frequently.
Version 2.0	7/06/12	<ul style="list-style-type: none"> Added services for platforms, ballasts, lamps, and commercial refrigerators Added section to describe proper use of tested model name and number
Version 1.9	6/28/12	<ul style="list-style-type: none"> Added service for Roof Products
Version 1.8	6/1/12	<ul style="list-style-type: none"> Added System Maintenance Schedule
Version 1.7	4/10/12	<ul style="list-style-type: none"> Added services for Water Coolers, GU24 Fluorescent, Boilers, Vending Machines, Battery Charging Systems, and Enterprise Servers
Version 1.6	3/20/12	<ul style="list-style-type: none"> Added services for Telephony, LCHVAC, and Griddles
Version 1.5	3/16/12	<ul style="list-style-type: none"> Added services for Furnaces 3.0 and Furnaces 4.0 for CB Testing
Version 1.4	2/20/12	<ul style="list-style-type: none"> Added CAC/ASHP web-service Updated Naming conventions, added section on standards Added Namespaces column to Web-services section Removed XML Spy generated message stubs
Version 1.3	1/6/12	<ul style="list-style-type: none"> Updated documentation to annotate addition of Dehumidifiers 3.0 template which will enter testing phase. Updated error code table with new error codes
Version 1.2	12/22/11	<ul style="list-style-type: none"> Added clarification in multiple places concerning ESUM_ID and its permanency throughout the life-cycle of a model.
Version 1.1	11/29/11	<ul style="list-style-type: none"> Updated Unique Identifier information based on feedback from CB Technical Webinar Updated Web-service table to reflect change of GHP test service to allow all CBs to test against GHP Added Version control table
Version 1.0	10/21/11	<ul style="list-style-type: none"> Initial release version