

UNITED STATES ENVIRONMENTAL PROTECTION AGENCY
WASHINGTON, D.C. 20460



OFFICE OF
AIR AND RADIATION

April 7, 2017

Dear Electric Vehicle Supply Equipment (EVSE) Partner or Other Interested Stakeholder:

On December 27, 2016, The U.S. Environmental Protection Agency (EPA) finalized the Version 1.0 ENERGY STAR® EVSE Program Requirements. Since that time, as products have begun to be tested for certification, stakeholders have sought a few clarifications. Based on their questions, EPA made modest edits to the specification and the test method to clarify the requirements, as noted below and illustrated in the Appendix to this letter. The revised documents, marked “Rev. Apr-2017”, have replaced the existing final documents on the ENERGY STAR website.

Clarifications to Definitions:

- In requiring ENERGY STAR certified EVSE to be NRTL listed for safety per Section 3.2.1, EPA seeks to ensure that labeled products are meeting industry safety standards. Stakeholders have noted that listing ‘Safety Functions’ as an example of a Secondary Function could be interpreted as the specification defining in which operational modes safety functions should be engaged. For clarity that EPA’s intention is to harmonize with industry safety standards, letting them specify how safety features should be implemented, EPA has removed mention of safety functions as an example under the Secondary Functions definition. EPA maintains the requirement that each EVSE be NRTL listed for safety.
- EPA has removed the mention of only Tertiary Functions being engaged in No Vehicle Mode, after noting that some Secondary Functions, such as display illumination, may be engaged in No Vehicle Mode. EPA has maintained the physical description of the No Vehicle mode to differentiate it from the other defined modes.

Test Method Clarifications:

- For test setup, ‘Receptacle or Hardwire Connection’ and SAE J1772 Vehicle Inlet Connection are to be located in relation to the measurement points, V_{in} , V_{diff1} , V_{diff2} , I_{in1} , I_{diff1} , and I_{out2} shown in Figure 1b.
- Power calculations for each mode should be calculated as the integral of voltage and current over one period, divided by the length of the period. This represents average power, as opposed to apparent power. Previously, the calculations consisted simply of $I \times V$, which would be interpreted as apparent power, which was not EPA’s intention.
- The Qualified Product Exchange (QPX), which is used by Certification Bodies to submit the results of testing to EPA’s database, requires the input and output power values for Operation Mode. EPA has now included these equations and expressed total power loss in terms of these constituent parts.
- Section 5.5.A) Full Network Connectivity Testing: In Section 6.7.5.2 of Consumer Electronics Association (CEA) 2037-A, two methods are outlined to verify the availability of Standby-active, Low Mode, or Partial On Mode for EVSE. Since the second method is not viable for EVSE, as it would require switch S2 to remain open when the unit under test is switched into Operation Mode, EPA has clarified that Method 1 should be used to determine the availability of Full Network Connectivity.

Thank you for your continued support of the ENERGY STAR program. Please contact me at (202) 343-9845, or Radulovic.Verena@epa.gov, or Emmy Feldman at (202) 862-1145, or Emmy.Feldman@icf.com, with any questions or comments regarding this specification and test method update.

Sincerely,

A handwritten signature in cursive script that reads "Verena Radulovic".

Verena Radulovic, Manager
ENERGY STAR for Consumer Electronics

Enclosures:

Final Version 1.0 ENERGY STAR Specification for EVSE (Rev. Mar-2017)

Final ENERGY STAR Test Method for EVSE (Rev. Mar-2017)

Appendix:
Illustrated Clarifications to the ENERGY STAR Test Method for Electric Vehicle Supply Equipment

Figure 1b:

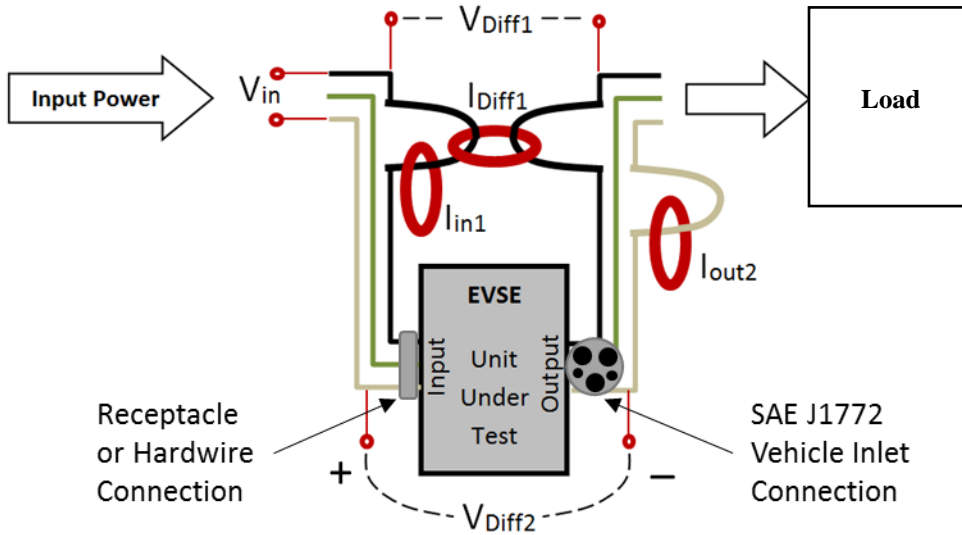

- EPA has indicated in Figure 1b where the ‘Receptacle or Hardwire Connection’ and SAE J1772 Vehicle Inlet Connection are located in relation to the measurement points, V_{in} , V_{diff1} , V_{diff2} , I_{in1} , I_{diff1} , and I_{out2} .

Section 5.2.D), and 5.3.D)

- EPA has clarified that the power calculations for each mode should be calculated as the integral of voltage and current over one period, divided by the length of the period. This represents average power, as opposed to apparent power. Previously, the calculations consisted simply of $I \times V$, which would be interpreted as apparent power. These clarifications to the equations are outlined below:
 - Input Power for No Vehicle Mode:
 - For single-output: $P = \frac{1}{T} \int_0^T v_{in}(t) \times i_{diff1}(t) dt$
 - For multiple-output: $P = \frac{\frac{1}{T} \int_0^T v_{in}(t) \times i_{diff1}(t) dt}{n}$
 - Input Power for Operation Mode:
 - For single-output: $P = \frac{1}{T} \int_0^T v_{in}(t) \times i_{diff1}(t) dt$
 - For multiple-output: $P = \frac{\frac{1}{T} \int_0^T v_{in}(t) \times i_{diff1}(t) dt}{n}$
 - Input Power for Partial On Mode:
 - For single-output: $P = \frac{1}{T} \int_0^T v_{in}(t) \times i_{diff1}(t) dt$
 - For multiple-output: $P = \frac{\frac{1}{T} \int_0^T v_{in}(t) \times i_{diff1}(t) dt}{n}$

Section 5.4.E)

- The Qualified Product Exchange (QPX), which is used by Certification Bodies to submit the results of testing to EPA’s database, requires the input and output power values for Operation Mode. Since the Test Method previously did not have these two calculations clearly defined, EPA has included these equations and expressed total power loss in terms of these constituent parts:
 - For single-output:

$$P_{INPUT} = \frac{1}{T} \int_0^T i_{diff1}(t) \times v_{in}(t) dt$$

$$P_{OUTPUT} = \frac{1}{T} \int_0^T (i_{out2}(t) \times v_{diff2}(t) - i_{in1}(t) \times v_{diff1}(t)) dt$$

$$P_{loss} = P_{INPUT} - P_{OUTPUT}$$

- For multiple-output:

$$P_{INPUT_i} = \frac{1}{T} \int_0^T i_{diff1i}(t) \times v_{in}(t) dt$$

$$P_{OUTPUT_i} = \frac{1}{T} \int_0^T (i_{out2}(t) \times v_{diff2}(t) - i_{in1}(t) \times v_{diff1}(t)) dt$$

$$P_{OUTPUT} = \frac{\sum_{i=1}^n P_{OUTPUT_i}}{n}$$

$$P_{INPUT} = \frac{\sum_{i=1}^n P_{INPUT_i}}{n} - (n-1) \times \frac{\frac{1}{T} \int_0^T v_{in}(t) \times i_{diff1}(t) dt}{n} \Bigg|_{\text{Partial On}}$$

$$P_{loss} = P_{INPUT} - P_{OUTPUT}$$