



ENERGY STAR® Program Requirements For Connected Thermostat Products

Partner Commitments

Following are the terms of the ENERGY STAR Partnership Agreement as it pertains to the provision and labeling of ENERGY STAR connected thermostat (CT) products. The ENERGY STAR Partner must adhere to the following partner commitments:

Providing Certified Connected Thermostat Products

1. Partner must be a connected thermostat service provider.
2. Comply with current ENERGY STAR Connected Thermostat Products Eligibility Criteria, which define performance requirements and test procedures. A list of eligible products and their corresponding Eligibility Criteria can be found at www.energystar.gov/specifications.
3. Prior to associating the ENERGY STAR name or mark with any product, obtain written certification of ENERGY STAR certification from a Certification Body recognized by EPA for Connected Thermostat products. As part of this certification process, products must be tested in a laboratory recognized by EPA to perform CT device testing. A list of EPA-recognized laboratories and Certification Bodies can be found at www.energystar.gov/testingandverification.
4. A new CT product is defined as having either significantly different hardware or software features relative to an existing CT product. CT products receiving software updates are not considered new CT products.

Using the ENERGY STAR Name and Marks

5. Comply with current ENERGY STAR Identity Guidelines, which define how the ENERGY STAR name and marks may be used. Partner is responsible for adhering to these guidelines and ensuring that its authorized representatives, such as advertising agencies, dealers, and distributors, are also in compliance. The ENERGY STAR Identity Guidelines are available at www.energystar.gov/logouse.
6. Use the ENERGY STAR name and marks only in association with certified CT products, where the CT service and CT device have been certified together. The Partner may not refer to itself as an ENERGY STAR Partner unless at least one product is certified and offered for sale in the U.S. and/or ENERGY STAR partner countries.
7. Provide clear and consistent labeling of ENERGY STAR CT products.
 - 7.1. Electronic ENERGY STAR certification marks of at least 76x78 pixels in cyan, black or white shall be on the home screen, the main menu screen, or another place where users would be expected to come across it in routine use of the mobile app or web portal (if they exist).
 - 7.2. The ENERGY STAR mark shall be clearly displayed in CT service provider product literature (i.e., user manuals, spec sheets, etc.) and on the partner's Internet site where information about ENERGY STAR certified products is displayed.
 - 7.3. The ENERGY STAR mark shall not be physically applied to the CT device packaging unless the CT device brand owner also brands a CT service that is certified with the CT

device as ENERGY STAR, or the CT device is co-branded with a default CT service that is ENERGY STAR certified, and the installer/user is guided towards the use of that CT service.

7.4. ENERGY STAR marks shall not be applied to the CT device including physical marks on the CT device and electronic marks in the CT Device user interface.

8. ENERGY STAR Labeling of CT products that are associated with a broader product, such as a home security system, shall clearly indicate that only the CT product is certified. Neither physical nor electronic labels shall be associated with the broader product, and product literature shall state: *"This [insert product type (e.g., security system, home automation system)] includes an ENERGY STAR Certified Connected Thermostat. Only the Connected Thermostat is certified as ENERGY STAR."*

Providing Information to EPA

9. Provide aggregate savings data and associated statistics to EPA every 6 months in accordance with the ENERGY STAR Method to Demonstrate Connected Thermostat Field Savings. Submitted data shall be representative of savings for the CT product's U.S. installed base and must demonstrate continued compliance with the requirements of the specification. This data will also be used for program evaluation purposes:
 - 9.1. Every February 1, submit the ENERGY STAR CT Field Savings software tool output file for the previous January 1 through December 31 reporting period.
 - 9.2. Every July 1, submit the ENERGY STAR CT Field Savings software tool output file for the previous June 1 through May 31 reporting period.
10. Participate in verification of CT device hardware through a Certification Body recognized by EPA for Connected Thermostats, providing full cooperation and timely responses. EPA may also, at its discretion, conduct tests on CT products that are referred to as ENERGY STAR certified. These products may be obtained on the open market, or voluntarily supplied by Partner at the government's request.
11. Provide unit shipment data or other market indicators to EPA or an EPA-authorized third party annually to assist with creation of ENERGY STAR market penetration estimates, as follows:
 - 11.1. Partner must submit the total number of units newly subscribing to the CT service portion of ENERGY STAR certified CT products within the calendar year or an equivalent measurement as agreed to in advance by EPA and Partner.
 - 11.2. Partner must provide subscription data segmented by meaningful product characteristics (e.g., controlled system types, presence of additional functions) as prescribed by EPA.
 - 11.3. Partner must submit subscription data for each calendar year to EPA or an EPA-authorized third party, preferably in electronic format, no later than March 1 of the following year.

Submitted unit shipment data will be used by EPA only for program evaluation purposes and will be closely controlled. If requested under the Freedom of Information Act (FOIA), EPA will argue that the data is exempt. Any information used will be masked by EPA so as to protect the confidentiality of the Partner.

12. Report to EPA any attempts by recognized laboratories or Certification Bodies (CBs) to influence testing or certification results or to engage in discriminatory practices.
13. Notify EPA of a change in the designated responsible parties or contacts within 30 days using the My ENERGY STAR Account tool (MESA) available at www.energystar.gov/mesa.

Training and Consumer Education

14. Partner shall train distributors, sales staff and installation contractors on the value of the ENERGY STAR program. This training shall include, at a minimum, identification of ENERGY STAR certified products within the Partner's offerings and on the Partner's web site.
15. All consumer information documents – operating manuals, installation instructions, etc.—must be easily accessible to consumers on a public website.

Performance for Special Distinction

In order to receive additional recognition and/or support from EPA for its efforts within the Partnership, the ENERGY STAR Partner may consider the following voluntary measures, and should keep EPA informed on the progress of these efforts:

- Provide quarterly, written updates to EPA as to the efforts undertaken by Partner to increase availability of ENERGY STAR certified products, and to promote awareness of ENERGY STAR and its message.
- Consider energy efficiency improvements in company facilities and pursue benchmarking buildings through the ENERGY STAR Buildings program.
- Purchase ENERGY STAR certified products. Revise the company purchasing or procurement specifications to include ENERGY STAR. Provide procurement officials' contact information to EPA for periodic updates and coordination. Circulate general ENERGY STAR certified product information to employees for use when purchasing products for their homes.
- Feature the ENERGY STAR mark(s) on Partner website and other promotional materials. If information concerning ENERGY STAR is provided on the Partner website as specified by the ENERGY STAR Web Linking Policy (available in the Partner Resources section of the ENERGY STAR website), EPA may provide links where appropriate to the Partner website.
- Ensure the power management feature is enabled on all ENERGY STAR certified displays and computers in use in company facilities, particularly upon installation and after service is performed.
- Provide general information about the ENERGY STAR program to employees whose jobs are relevant to the development, marketing, sales, and service of current ENERGY STAR certified products.
- Provide a simple plan to EPA outlining specific measures Partner plans to undertake beyond the program requirements listed above. By doing so, EPA may be able to coordinate, and communicate Partner's activities, provide an EPA representative, or include news about the event in the ENERGY STAR newsletter, on the ENERGY STAR website, etc. The plan may be as simple as providing a list of planned activities or milestones of which Partner would like EPA to be aware. For example, activities may include: (1) increasing the availability of ENERGY STAR certified products by converting the entire product line within two years to meet ENERGY STAR guidelines; (2) demonstrating the economic and environmental benefits of energy efficiency through special in-store displays twice a year; (3) providing information to users (via the website and user's manual) about energy-saving features and operating characteristics of ENERGY STAR certified products; and (4) building awareness of the ENERGY STAR Partnership and brand identity by collaborating with EPA on one print advertorial and one live press event.
- Join EPA's SmartWay Transport Partnership to improve the environmental performance of the company's shipping operations. The SmartWay Transport Partnership works with freight carriers, shippers, and other stakeholders in the goods movement industry to reduce fuel consumption, greenhouse gases, and air pollution. For more information on SmartWay, visit www.epa.gov/smartway.
- Join EPA's Green Power Partnership. EPA's Green Power Partnership encourages organizations to buy green power as a way to reduce the environmental impacts associated with traditional fossil fuel-based electricity use. The partnership includes a diverse set of organizations including Fortune

500 companies, small and medium businesses, government institutions as well as a growing number of colleges and universities. For more information on Green Power, visit www.epa.gov/greenpower.



ENERGY STAR Program Requirements

Product Specification for Connected Thermostat Products

Eligibility Criteria

Version 1.0

Rev. Jan 2017

Following are the eligibility requirements for the Version 1.0 ENERGY STAR Connected Thermostats program. Connected Thermostat (CT) products shall meet all of the identified criteria to earn the ENERGY STAR.

1) Definitions:

- A. Communication Link: The mechanism for bi-directional data transfers between the CT device and one or more external applications, devices or systems.
- B. Connected Thermostat Device: A device that controls heating, ventilation, and air-conditioning (HVAC) equipment to regulate the temperature of the room or space in which it is installed, and has the ability to communicate with sources external to the HVAC system. For connection, the CT device may rely on a Wi-Fi home area network and an internet connection that is independent of and not part of the CT Device. Where the CT device relies upon other devices that are not reasonably expected to be in the home, e.g. Zigbee gateway, these devices are part of the CT device.
- C. Connected Thermostat Product: For the purposes of this specification, the CT product includes the CT device in the home with associated firmware, which is assumed to be updated during the time the CT device is used in the home, as well as a CT service supported by hardware and software outside of the home. The CT service would typically provide web and smart phone based thermostat control. See Figure 1 for a pictorial representation. Functions in the left-most group must be physically located in the home. Functions in the middle group commonly operate using a combination of hardware that is physically located within the home and services that rely fully or partially on communication with the cloud. The functions on the right typically reside in the cloud.

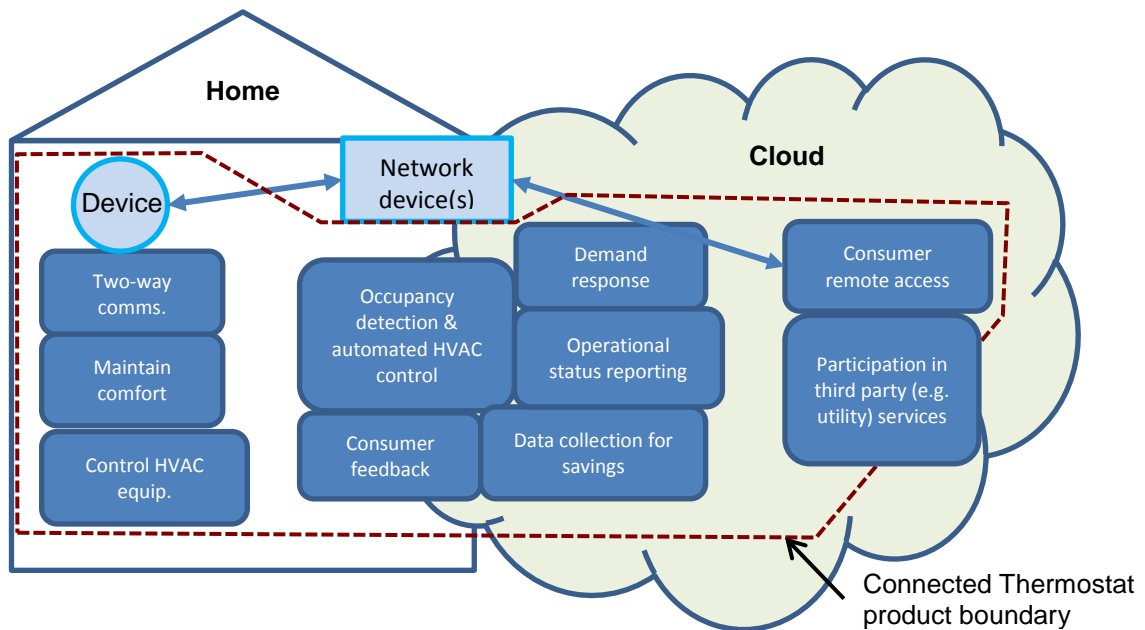

Figure 1: Connected Thermostat Product

- D. Connected Thermostat Service Provider: The organization that brands the CT service. CT services typically include smart phone and web control applications, messaging relevant to energy consumption, and application programming interfaces (API) that enable consumer-authorized interconnection with utilities and other 3rd parties.
- E. Core Heating Day/Core Cooling Day: A core heating day has more than 30 minutes of heating equipment run time and no cooling equipment run time. Similarly, a core cooling day has more than 30 minutes of cooling equipment run time and no heating equipment run time.
- F. Demand Response (DR): Changes in electric usage by demand-side resources from their normal consumption patterns in response to changes in the price of electricity over time, or to incentive payments designed to induce lower electricity use at times of high wholesale market prices or when system reliability is jeopardized¹.
- G. Demand Response Management System (DRMS): The system operated by a program administrator, such as the utility or third party, which dispatches signals with DR instructions and/or price signals to the ENERGY STAR CT products and receives messages from the CT product.
- H. Interface Specification: A document or collection of documents that contains detailed technical information to facilitate access to relevant data and product capabilities over a communications interface
- I. Line Voltage Thermostat: Thermostat that is powered by and/or switches > 30 Vac.
- J. Load Management Entity: DRMS, home energy management system, and the like.
- K. Network Standby: A state where the CT device is:
 1. installed and interconnected in accordance with provided instructions,
 2. with no direct or remote user interaction (e.g., smart phone app, web interface, occupancy detection), and
 3. sufficient time has elapsed to allow the CT device to enter a low power state, as applicable.

¹ Federal Energy Regulatory Commission, <https://www.ferc.gov/industries/electric/indus-act/demand-response/dr-potential.asp>

For example, the screen has dimmed or turned off automatically.

- L. Open Standards: Communication with entities outside the connected thermostat that use, for all communication layers, standards:
 - included in the Smart Grid Interoperability Panel (SGIP) Catalog of Standards,² and/or
 - included in the NIST Smart Grid Framework Tables 4.1 and 4.2, and/or
 - adopted by the American National Standards Institute (ANSI) or another well-established international standards organization such as the International Organization for Standardization (ISO), International Electrotechnical Commission (IEC), International Telecommunication Union (ITU), Institute of Electrical and Electronics Engineers (IEEE) or Internet Engineering Task Force (IETF).
- M. Product Family: A group of closely related CT products sharing a primary strategy for delivering savings, and using similar CT devices. All members of a product family shall share one score on the field savings metrics for heating and cooling. CT products using different strategies to produce savings shall be in different product families.
- N. Static Temperature Accuracy: The deviation in the room temperature displayed and/or communicated by the CT device from 70°F (21°C); after one hour in a calibrated temperature chamber set to 70°F (21°C).³

2) Scope:

- A. Included Products: Only products that meet the definition of a CT product, as specified herein, are eligible for ENERGY STAR certification. CT products provided as part of a larger product offering, such as a home security system, may be certified but will be subject to specific labeling requirements.
- B. Excluded Products:
 - 1 CT products that are unable to collect the required data for the energy savings metric as required by Section 3) B.4.
 - 2 Line voltage thermostats.

3) Eligibility Criteria:

- A. Connected Thermostat Device Requirements:

Each CT device in a product family shall fulfill these requirements:

 - 1. In the absence of connectivity to the CT service provider, retain the ability for residents to locally:
 - a. view the room temperature,
 - b. view and adjust the set temperature, and
 - c. switch between off, heating and cooling.

² http://collaborate.nist.gov/wiki-sggrid/bin/view/SmartGrid/PMO#Catalog_of_Standards_Processes

³ The static temperature accuracy definition is based on requirements in National Electrical Manufacturers Association (NEMA) DC 3, Annex A 2013 Energy-Efficiency Requirements for Programmable Thermostats.

2. Meet requirements set out in Table 1, below:

Table 1: Connected Thermostat Device Criteria

Parameter	Performance Requirement	Applicable Products
Static temperature accuracy	$\leq \pm 2.0$ °F	All
Network standby average power consumption ⁱ	≤ 3.0 W average	
Time to enter network standby after user interaction (on device, remote or occupancy detection)	≤ 5.0 minutes	

i Includes all equipment necessary to establish connectivity to the CT service provider's cloud, except those that can reasonably be expected to be present in the home, such as Wi-Fi routers and smart phones.

- B. Connected Thermostat Product Requirements: The following capabilities may be enabled through the CT device, CT service or any combination of the two. The CT product shall maintain these capabilities through subsequent firmware and software changes. The CT service provider shall maintain documentation that demonstrates compliance to these requirements. Initial certification of these requirements will be based on a review of product literature.
1. Ability for consumers to set and modify a schedule.
 2. Provision of feedback to occupants about the energy impact of their choice of settings.
 3. Ability for consumers to access information relevant to their HVAC energy consumption, e.g., HVAC run time.
 4. The CT product shall be capable of collecting the following data, including where noted, to the indicated resolution and accuracy:
 - a. Unique thermostat ID
 - b. ZIP code (installed location)
 - c. Controlled HVAC equipment type to the extent it can be determined by the CT product:
 - Single-stage heat pump with electric resistance auxiliary and/or emergency heat (i.e. strip heat)
 - Single-stage heat pump without additional and/or supplemental heating sources
 - Single-stage non heat pump with single-stage central air conditioning
 - Single-stage non heat pump without central air conditioning
 - Single-stage central air conditioning without central heating
 - Other – e.g. multi-zone multi-stage, modulating
 - d. Daily cooling equipment run time (reported to the nearest minute)
 - e. Daily heating equipment run time (reported to the nearest minute)
 - f. Hourly auxiliary heat run time (reported to the nearest minute)
 - g. Hourly emergency heat run time (reported to the nearest minute)
 - h. Hourly average conditioned space temperature (reported to nearest 0.5°F)
 - i. Hourly average heating set point temperature (reported to nearest 1.0°F)
 - j. Hourly average cooling set point temperature (reported to nearest 1.0°F)
 5. Demand Response
 - a. Grid Communications – The CT product shall include a communication link that facilitates the use of open standards, as defined in this specification, for all communication layers to enable DR functionality.

Note: CT products that enable direct, on-premises, open-standards based interconnection are preferred, but alternative approaches, where open-standards connectivity is enabled only with use of off-premise services, are also acceptable.
 - b. Open Access – To enable interconnection with the CT product over the communication link, an interface specification, application programming interface (API) or similar documentation shall be made available that, at a minimum, enables DR functionality.

Note: While EPA encourages broad availability of the interface spec or API, CT service providers may elect to limit dissemination of these documents to certified/qualified developers, integration partners and the like.

- c. Consumer Override – Consumers shall be able to override their CT product’s response to any DR signal.
 - d. Capabilities Summary – A ≤ 250-word summary description of the CT product’s and/or associated CT service provider’s DR capabilities/services shall be submitted. In this summary, EPA recommends noting the following, as applicable:
 - DR services that the CT product has the capability to participate in such as load dispatch, ancillary services, price notification and price response.
 - Whether the CT device can be directly addressed via the interface specification, API or similar documentation.
 - Support for locational DR, e.g. to ZIP code(s), feeder(s), or to CT device endpoints specified by the Load Management Entity.
 - List open communications supported by the CT device and/or CT service, including applicable certifications.
 - Feedback to Load Management Entity, e.g. verification/M&V, override notification.
 - Measures to limit consumer comfort impacts, if any.
 - DR response configurability/flexibility by the consumer and/or Load Management Entity.
 - Whether the CT device and/or the CT product comply with the [2016 California Energy Commission Title 24, Part 6 Joint Appendix 5](#).
- C. Field Savings: CT products shall demonstrate typical product performance in the field by one of two methods. To be certified, CT products must have at least 12 months of interval data. The end of the 12 month period analyzed for initial certification shall be no more than 6 months before the analysis is submitted for certification. These requirements refer to reported performance of the CT product.
1. Metric Performance:

Table 2: Connected Thermostat Energy Savings Criteria

Metric	Statistical measure	Performance Requirement
Annual % run time reduction, heating (HS)	Lower 95% confidence limit of weighted national average	≥ 8%
	Weighted national average of 20 th percentiles	≥ 4%
Annual % run time reduction, cooling (CS)	Lower 95% confidence limit of weighted national average	≥ 10%
	Weighted national average of 20 th percentiles	≥ 5%
Average resistance heat utilization for heat pump installations (RU)	National mean in 5°F outdoor temperature bins from 0 to 60°F	Reporting requirement

2. A/B Study: In lieu of meeting metric performance requirements outlined in Table 2, partner may propose an A/B study which demonstrates the mean reduction of run time (or mean reduction in energy use) for homes using their CT product as compared to a typical thermostat. To earn the ENERGY STAR, field savings studies shall show that the lower 95% confidence limit of run time reduction for heating is at least 6% and for cooling is at least 7%. In addition, studies shall show that no more than 20% of homes in the study showed savings of 1% or lower in heating or in cooling. Partners using this allowance shall also apply the ENERGY STAR Method to Demonstrate Connected Thermostat Field Savings and submit the output at time of certification and periodically as required for all CT products. All studies must be pre-approved and shall meet the following requirements:
 - a. Two groups of consumers shall have products present in their home that they use as the thermostat(s) for their homes during the study period. The test group shall have capabilities available equivalent to the CT products the study covers. The control group shall have capabilities available to them that represent a typical thermostat and provide a reasonable baseline for comparison.
 - b. Both groups of consumers shall be large enough, and will use the products for a sufficient length of time, to estimate savings on core heating and cooling days with statistically significant results.
 - c. Results of the study will be lower 95% confidence limit of the mean % run time reduction or mean % energy savings in the test group compared to the control group, for both heating and cooling as required by the specification. The confidence limit may be calculated with the simplifying assumption that the relative energy or run time reduction has a Gaussian distribution around the mean.
 - d. If only a smaller sample of homes is available, a study design using a pre-study matching period in which test and control groups have access to the same capabilities may be proposed. Application of a correction factor derived from the comparison of groups in the pre-test period may be used to account for fluctuations in home properties between groups. In this case, the pre-test and test periods shall be as close together in time as possible, and the uncertainty shall be estimated as half what it would have been without the correction from the pre-test period.
 - e. Results of the study shall be representative of mean savings across the U.S.
 - f. The study shall provide a method for ongoing monitoring of results, equivalent to semi-annual reporting of metric scores. This may involve periodically re-running the study on a smaller set of consumers, for instance.

Process

- a. Partner shall submit a proposal for the study to EPA, demonstrating compliance with the study requirements. This is expected to be an iterative process involving conversation between the Partner and EPA. EPA will post proposed studies to a publically accessible web page during the period they are under consideration.
- b. Once the study design is approved, the Partner will execute the study and report the results to EPA. Results shall include at minimum the mean percent HVAC run time or HVAC energy use reduction from the control group to the test group, the associated 95% confidence limits of the mean, and the 20th percentile of these quantities across homes.
- c. EPA will confirm whether results meet the requirements of the specification and will publish successful studies.

D. Significant Digits and Rounding:

1. All calculations shall be carried out with directly measured (unrounded) values.

2. Unless otherwise specified below, compliance with specification limits shall be evaluated using directly measured or calculated values rounded to the nearest 0.1°F.
3. Directly measured or calculated values that are submitted for reporting on the ENERGY STAR website shall be rounded to the nearest significant digit as expressed in the corresponding specification limit.

4) Test Requirements:

A. Product Families: A product family may be established under the following circumstances:

1. Each CT device that is part of a CT product within the product family is separately tested to ensure it meets the requirements in section 3) A.
2. Each CT service/CT device combination shall comply with section 3) B.
3. All members of the product family use the same primary savings strategy or strategies.
4. All installations within a product family shall be considered as a single population for determining field savings, and the metric performance scores shall apply to all members of the product family.

Examples of allowable variations within a product family:

- *For CT products that derive savings from automatic temperature changes without prompting users, the user interface differences of CT devices would be irrelevant.*
- *For CT products that rely on occupancy detection to deliver savings, including motion sensing by the CT device and CT services that track occupants via mobile device location services:*
 - *CT products with similar occupancy detection can be in the same product family.*
 - *CT products with dissimilar occupancy detection would fall into different product families, unless the occupancy detection is not part of a primary savings strategy.*
- *For CT products that can provide different services in different utility service territories based on utility program offerings, (e.g. precooling is available in areas with time-of-use rates); these variations can be in a single product family, as long as they do not impact primary savings strategies.*
- *For CT products that include the capability to add services that may increase energy savings, all variations may be in the same product family.*

B. Software updates: Software updates are expected to not affect product savings, or to increase savings, and do not require recertification. Software changes that alter the principle that savings rest upon, or which are expected to reduce savings, would define a new product and would require a new certification.

C. Test Methods:

The following methods shall be used to demonstrate ENERGY STAR certification:

Table 3: Test Methods for ENERGY STAR Certification

ENERGY STAR Requirement	Test Method Reference
Functionality in the absence of connectivity	As per section 4) D. and 4) E. below
Static temperature accuracy	As per section 4) D. and 4) F. below
Network standby power consumption	IEC 62301, Ed. 2.0, 2011-01, Household electrical appliances – Measurement of standby power, subject to clarifications in section 4) D. and 4) G. below
Time to standby	
Reduction in average annual % run time, heating (HS)	ENERGY STAR Method to Demonstrate Connected Thermostat Field Savings, V1.0
Reduction in average annual % run time cooling (CS)	
Average resistance heat utilization for heat pump installations (RU)	

D. Connected Thermostat Device Configuration for Testing

1. Configure and provision the Unit Under Test's (UUT) connected functionality, including enrollment of applicable services and updating to latest version of firmware.

E. Functionality in the Absence of Connectivity

1. Install and configure the CT device either into a test environment or to control compatible HVAC heating and cooling source equipment. Ensure that the test setup enables observation of the UUT's HVAC control signals or actions, e.g. monitoring the UUTs wiring terminals for state changes or observing switching of HVAC equipment.
2. Disable connectivity, for example by shutting down the Wireless LAN.
3. Verify (pass/fail) the capability for a user to interact with the CT device to:
 - a. Observe the room temperature,
 - b. Observe and adjust the setpoint, and
 - c. Switch between off, heating and cooling

F. Static Temperature Accuracy

1. Install and configure four CT devices and four temperature sensors with a calibrated temperature logger onto a ½" wallboard panel with at least 3" separation between each UUT and temperature sensor or logger. The temperature sensors/logger shall have minimum ±0.1°F accuracy.
2. Suspend the wallboard panel in the center of a thermal chamber ensuring at least 12" of separation from chamber walls, ceiling and floor.

Mounting the UUTs in this manner approximates typical mounting in homes. Keeping the mounting panel and the CT devices at least a foot from the chamber minimizes the effect of any heat radiating off of these surfaces. CT devices generate a small amount of heat. Maintaining a 3" or greater separation between adjacent CT devices and temperature loggers will minimize the effects of adjacent CT devices on measured temperatures.

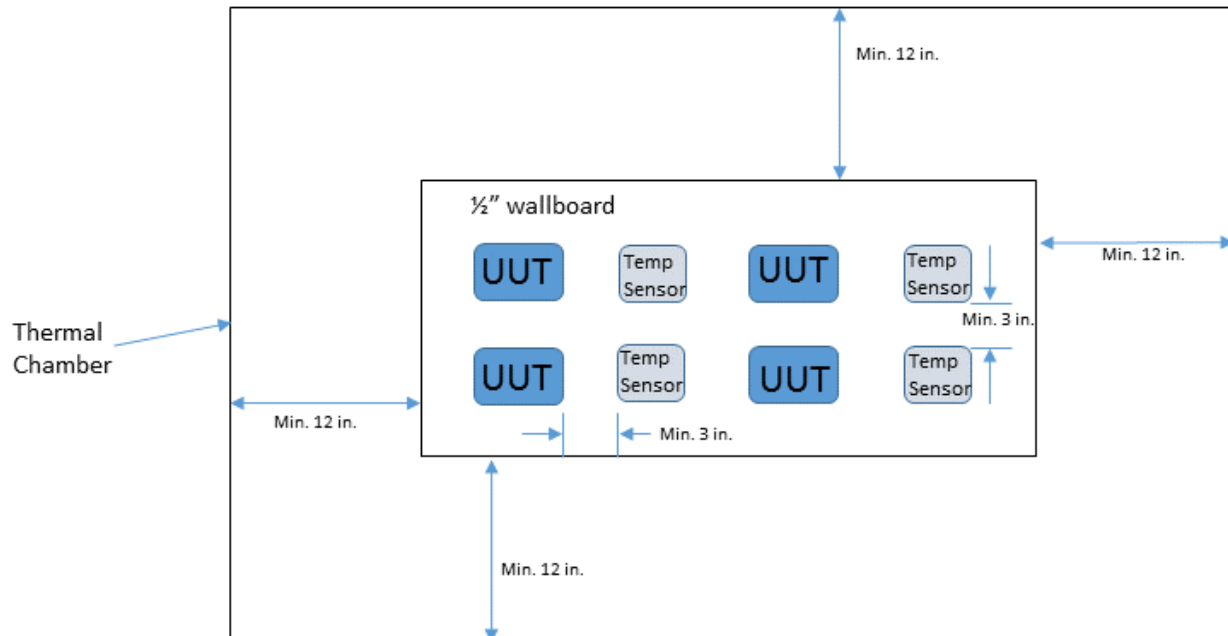

Figure 2: Typical Test Setup

3. Provide power to each UUT. It is unnecessary to connect to HVAC heating and cooling source equipment or to monitor the UUTs wiring terminals. Ensure that the test setup enables observation of the UUTs indoor temperature reading.
4. Configure the CT communications, connect to the default CT service and ensure the CT devices are able to maintain a connectivity with the chamber door closed.

While attempting to re-establish communications, certain CTs are known to generate additional internal heat that can impact temperature accuracy. By ensuring a stable link status, CTs will be tested in their normal operational mode.

5. Configure the UUTs so that they will not be calling for heating, fan, or cooling at the test temperature of 70°.
6. Test Conduct
 - a. Close the chamber door and set it to 70°F. Once this temperature is reached, chamber temperature shall be maintained at $70 \pm 0.5^\circ\text{F}$ for at least one hour.
 - b. Deactivate all thermal chamber fans. After deactivation, all temperatures recorded by each temperature sensor shall be within $70 \pm 2^\circ\text{F}$ for the remainder of this test.

For many temperature chambers, fans can only be deactivated by shutting down the chamber. In this scenario, the rate of temperature change will be dependent upon the ambient temperature in the lab. An ambient lab temperature of approximately 70°F should minimize the rate of change.

Fan-forced air flow in a thermal chamber is not representative of typical convection currents in a home and can impact the accuracy of temperatures displayed by the CT device.

- c. Record the difference between the room temperature displayed by each UUT and recorded by its adjacent temperature sensor at 30, 45 and 60 minutes after deactivating the fan. If a higher resolution temperature is reported over the communications link, use this as the UUT “displayed” temperature. (Test labs must generally work with CT service providers in order to obtain this data.)

- d. Calculate static temperature accuracy as the average of these 12 values.

G. Implementation of IEC 62301 for Connected Thermostat Testing

Note: This test is not applicable to UUTs or parts of UUTs (e.g. remote sensors) that are powered solely by batteries. Where the CT device relies upon other devices that are not reasonably expected to be in the home, e.g. Zigbee gateway, these devices are part of the CT device and shall be included in this test.

1. Assure that the CT device is appropriately configured as per section 4) B.
 - a. This test need not be performed in a temperature chamber.
 - b. Configure the UUT in accordance with the requirements of IEC 62301, Ed. 2.0, 2011-01, "Measurement of Household Appliance Standby Power," Section 4, "General Conditions for Measurements," unless otherwise noted in this document. In the event of conflicting requirements, this ENERGY STAR test method shall take precedence.
2. Test Conduct – Measure power consumption at the power input to the UUT using the sampling method, section 5.3.2 of IEC 62301, Edition 2.0 2011-01.
 - a. Verify ability to control the UUT over the communication link, then close all apps and web interfaces.
 - b. Increase the setpoint using the CT device controls.
 - c. Wait five minutes, while taking appropriate measures to allow the UUT to enter into and remain in network standby mode for the duration of the test, e.g.
 - No additional UUT user interactions,
 - Ensure occupancy sensing UUTs do not detect occupancy,
 - Ensure apps and/or web remote interfaces remain closed.
 - d. Separately measure and record average energy consumption over a five-minute period.
 - e. Check measurement stability in accordance with IEC 62301, Edition 2.0 2011-01, and section 5.3.2.
 - f. If stability criteria are not satisfied, repeat the test, starting from step 2. b, with the test period extended in five-minute increments (i.e. 10m, 15m, 20m...) as necessary to establish requisite measurement stability.
 - g. Once stable, repeat the test over two additional test periods, starting from step 2. b.
 - h. Record power consumption as the average over the second and third test periods.

5) **Effective Date:**

The ENERGY STAR Connected Thermostat specification shall take effect on December 23, 2016. To certify for ENERGY STAR, a Connected Thermostat Product shall meet the ENERGY STAR specification in effect on the date of connection. The date of connection is specific to each unit and is the date on which a unit is considered to be a Connected Thermostat Product.

6) **Future Criteria Revisions:**

EPA reserves the right to change the specification should technological and/or market changes affect its usefulness to consumers, industry, or the environment. In keeping with current policy, revisions to the specification are arrived at through industry discussions. In the event of a specification revision, please note that the ENERGY STAR certification is not automatically granted for the life of a CT product model.

Several topics that are likely to be examined in ongoing work and/or in future revisions have been identified. Some pertain only to the specification and others to the metric. They include:

- A. Reduction of CT device standby power to better reflect best practice.

- B. Refinement of the CT device static temperature accuracy test, to enable a more stringent performance requirement.
- C. If resistance heat utilization data indicates substantial variance among certified CT products, EPA may consider including requirements to ensure ENERGY STAR CT products effectively minimize the use of supplemental electric-resistance heat,
- D. For the Method to Demonstrate CT Field Savings, and associated software:
 - a. Exploring the potential to use average comfort temperature baselines that vary geographically. Such baselines are expected to capture a wider variety of primary savings strategies.
 - b. Exploring the potential to include CTs that control variable capacity equipment.
 - c. Incorporating weather normalization, to enable comparison of savings from different calendar years.
 - d. Further refining procedures to handle missing data.